

Biotic Transformations of Organic Contaminants

Bruce E. Rittmann



THE
GROUNDWATER
PROJECT

Biotic Transformations of Organic Contaminants

The Groundwater Project

Bruce E. Rittmann

*Regents Professor of Environmental Engineering
Director of the Biodesign Swette Center for Environmental Biotechnology
Arizona State University
Tempe, Arizona, USA*

***Biotic Transformations of Organic
Contaminants***

*The Groundwater Project
Guelph, Ontario, Canada*

SUSTAINABLE INNOVATIVE RESOURCES MANAGEMENT

Smart solutions for using resources efficiently,
protecting our planet, and securing
a prosperous future.



SECTORS



WATER



ENVIRONMENT



MINING
INTEGRATED WATER SERVICES
LIFECYCLE



GREEN ENERGY



DIGITIZATION
AND AUTOMATION



COMPREHENSIVE
MONITORING SOLUTIONS



DISASTER MANAGEMENT
SYSTEMS CATEGORY

SERVICES



The Groundwater Project relies on private funding for book production and management of the Project.

Please consider sponsoring the Groundwater Project so that our books will continue to be freely available. <https://gw-project.org/donate/>

Thank you.

All rights reserved. This publication is protected by copyright. No part of this book may be reproduced in any form or by any means without permission in writing from the author (to request permission contact: permissions@gw-project.org). Commercial distribution and reproduction are strictly prohibited.

Groundwater-Project (GW-Project) works are copyrighted and can be downloaded for free from gw-project.org. Anyone may use and share gw-project.org links to download GW-Project's work. It is not permitted to make GW-Project documents available on other websites nor to send copies of the documents directly to others. Kindly honor this source of free knowledge that is benefiting you and all those who want to learn about groundwater.

Copyright © 2023 Bruce E. Rittmann (The Author).

Published by the Groundwater Project, Guelph, Ontario, Canada, 2023.

Rittmann, Bruce E.

Biotic Transformations of Organic Contaminants / Bruce E.

Rittmann - Guelph, Ontario, Canada, 2023.

56 p.

ISBN: 978-1-77470-036-5

DOI: <https://doi.org/10.21083/OUSN4116>.

Please consider signing up to the GW-Project mailing list to stay informed about new book releases, events, and ways to participate in the GW-Project. When you sign up to our email list, it helps us build a global groundwater community. [Sign up](#).

APA 7th Edition Citation:

Rittmann, B. E. (2023). *Biotic transformations of organic contaminants*. The Groundwater Project. <https://doi.org/10.21083/OUSN4116>.



Domain Editors: John Cherry and Eileen Poeter.

Board: John Cherry, Shafick Adams, Richard Jackson, Ineke Kalwij, Renée Martin-Nagle, Everton de Oliveira, Marco Petitta, and Eileen Poeter.

Cover Image: The Groundwater Project, 2022.

Dedication

To my many students and colleagues, from whom I have learned so much.

Table of Contents

DEDICATION	v
TABLE OF CONTENTS	vi
THE GROUNDWATER PROJECT FOREWORD	viii
FOREWORD	ix
PREFACE	x
ACKNOWLEDGMENTS	xi
1 INTRODUCTION	1
2 THE BASICS OF MICROBIAL METABOLISM	2
2.1 ELECTRON DONORS AND ACCEPTORS.....	3
2.2 BIOMASS SYNTHESIS.....	4
2.3 CARRIERS OF ELECTRONS AND ENERGY.....	5
2.4 NORMAL CATABOLIC REACTIONS	6
2.4.1 Hydroxylation and Dehydrogenation.....	7
2.4.2 β -Oxidation.....	8
2.4.3 The Citric Acid Cycle.....	9
3 BIODEGRADATION OF ORGANIC CONTAMINANTS	11
3.1 ACTIVATION BY MONO- AND DI-OXYGENATIONS.....	11
3.2 S_{MIN} , SECONDARY UTILIZATION, AND CO-METABOLISM.....	13
3.3 HYDROPHOBICITY AND BIOAVAILABILITY	14
3.4 SOME COMPOUNDS NEED TO BE REDUCED.....	15
4 HYDROCARBONS	17
5 OXYGEN-CONTAINING ORGANICS OF SPECIAL INTEREST	20
6 CHLORINATED ALKANES AND ALKENES	23
7 CHLORINATED AROMATICS	26
8 ENERGETICS	30
9 FLUORINATED ALKYL SUBSTANCES	32
10 WRAP UP	34
11 EXERCISES	35
EXERCISE 1	35
EXERCISE 2	35
EXERCISE 3	35
EXERCISE 4	35
EXERCISE 5	36
EXERCISE 6	36
EXERCISE 7	36
EXERCISE 8	36
EXERCISE 9	36
EXERCISE 10	36
EXERCISE 11	37
EXERCISE 12	37
EXERCISE 13	37
EXERCISE 14	37

EXERCISE 15 38

EXERCISE 16 38

EXERCISE 17 39

EXERCISE 18 39

EXERCISE 19 40

EXERCISE 20 40

EXERCISE 21 40

EXERCISE 22 40

EXERCISE 23 40

EXERCISE 24 40

12 REFERENCES 42

13 EXERCISES SOLUTIONS..... 43

SOLUTION EXERCISE 1 43

SOLUTION EXERCISE 2 44

SOLUTION EXERCISE 4 45

SOLUTION EXERCISE 5 45

SOLUTION EXERCISE 6 45

SOLUTION EXERCISE 7 46

SOLUTION EXERCISE 8 46

SOLUTION EXERCISE 9 46

SOLUTION EXERCISE 10 46

SOLUTION EXERCISE 11 47

SOLUTION EXERCISE 12 47

SOLUTION EXERCISE 13 48

SOLUTION EXERCISE 14 48

SOLUTION EXERCISE 15 48

SOLUTION EXERCISE 16 49

SOLUTION EXERCISE 17 50

SOLUTION EXERCISE 18 51

SOLUTION EXERCISE 19 52

SOLUTION EXERCISE 20 52

SOLUTION EXERCISE 21 52

SOLUTION EXERCISE 23 53

SOLUTION EXERCISE 24 53

14 NOTATIONS 54

15 ABOUT THE AUTHOR 55

The Groundwater Project Foreword

At the United Nations (UN) Water Summit held in December 2022, delegates agreed that statements from all major groundwater-related events will be unified in 2023 into one comprehensive groundwater message. This message was released at the UN 2023 Water Conference, a landmark event that brought attention at the highest international level to the importance of groundwater for the future of humanity and ecosystems. This message brought clarity to groundwater issues to advance understanding globally of the challenges faced and actions needed to resolve the world's groundwater problems. Groundwater education is key.

The 2023 World Water Day theme *Accelerating Change* is in sync with the goal of the Groundwater Project (GW-Project). The GW-Project is a registered Canadian charity founded in 2018 and committed to the advancement of groundwater education as a means to accelerate action related to our essential groundwater resources. To this end, we create and disseminate knowledge through a unique approach: the democratization of groundwater knowledge. We act on this principle through our website gw-project.org/, a global platform, based on the principle that

“Knowledge should be free, and the best knowledge should be free knowledge.” Anonymous

The mission of the GW-Project is to promote groundwater learning across the globe. This is accomplished by providing accessible, engaging, and high-quality educational materials—free-of-charge online and in many languages—to all who want to learn about groundwater. In short, the GW-Project provides essential knowledge and tools needed to develop groundwater sustainably for the future of humanity and ecosystems. This is a new type of global educational endeavor made possible through the contributions of a dedicated international group of volunteer professionals from diverse disciplines. Academics, consultants, and retirees contribute by writing and/or reviewing books aimed at diverse levels of readers from children to high school, undergraduate and graduate students, or professionals in the groundwater field. More than 1,000 dedicated volunteers from 127 countries and six continents are involved—and participation is growing.

Hundreds of books will be published online over the coming years, first in English, and then in other languages. An important tenet of GW-Project books is a strong emphasis on visualization with clear illustrations to stimulate spatial and critical thinking. In future, the publications will also include videos and other dynamic learning tools. Revised editions of the books are published from time to time. Users are invited to propose revisions.

We thank you for being part of the GW-Project Community. We hope to hear from you about your experience with the project materials, and welcome ideas and volunteers!

The GW-Project Board of Directors

January 2023

Foreword

Many organic compounds of industrial origin occur in groundwater at concentrations commonly exceeding the safe drinking water standards. This has resulted in an active industry operating worldwide for the assessment and remediation of contaminated industrial, military, waste disposal, and other sites. Over time, many of these contaminants diminish in concentration due to in situ microbial processes, which can be collectively referred to as biodegradation. This book, *Biotic Transformations of Organic Contaminants*, describes how microorganisms mediate reactions to transform organic groundwater contaminants, often into innocuous products, naturally or with human-engineered intervention. It focuses on the most common categories of organic chemicals in groundwater, including PFAS, the most recent category to receive widespread attention. The author also discusses transformations that result in degraded groundwater quality due to incomplete degradation.

To understand biodegradation, it is necessary to appreciate that microbes are living entities and, like human beings, they require food, nutrients, and a hospitable environment. These needs render microbes our allies because they can thrive by biodegrading organic contaminants. This book is aimed at enabling the reader to think about the state of organic contaminants in groundwater in terms of basic parameters that govern whether or not degradation can or will occur. This sets the stage for understanding whether or not engineering intervention can accelerate degradation. The biochemical reactions that represent the transformations of the most important contaminant categories are shown as schematic equations to help the reader keep track of the reactants, reaction products, and energy flows.

The author, Bruce Rittmann, is Regents Professor of Environment Engineering and Director of the Swette Center for Environmental Biotechnology at the Biodesign Institute, both at Arizona State University. Dr. Rittmann has broad research interests in how microbes play a role in helping make human society more sustainable. He is a member of the U.S. National Academy of Engineering and received the Stockholm Water Prize in 2018 for contributions improving water treatment through environmental biotechnology. He has published over 830 journal articles, books, and book chapters, and he has 21 patents. Dr. Rittmann is well known for pioneering the development of biofilm fundamentals and contributing to their widespread use in the cleanup of contaminated waters, soils, and ecosystems.

John Cherry, The Groundwater Project Leader
Guelph, Ontario, Canada, November, 2023

Preface

Biotic Transformations of Organic Contaminants describes how microorganisms can transform groundwater contaminants into innocuous products. The transformations can occur without human intervention, such as in natural attenuation, or can be stimulated in various forms of engineered bioremediation. In either case, the transformations are mediated by microorganisms that must grow and sustain themselves using their normal metabolic processes.

Sometimes, the transformations of contaminants are part of microorganisms' normal metabolic processes. In other cases, the transformations are specialized reactions carried out by certain microorganisms. *Biotic Transformations of Organic Contaminants* lays the foundation for understanding the routine and the special, as well as how specialized processes interact with routine processes. This understanding will make it possible for readers to evaluate and manage biotic transformations that occur in the research on and practice of bioremediation.

Readers need to have a basic knowledge of chemistry to gain the most meaningful information from this book. This basic knowledge is what might be called college "freshman chemistry," which enables the reader to interpret chemical formulas and reactions written out in a linear format. The reactions also are shown in the "line and ball" structural format, which will be familiar to those who have taken organic chemistry. The reader also should be comfortable with the chemistry concepts of oxidation/reduction, acid/base, and hydrophobic/hydrophilic.

I began engaging with groundwater and the biological fate of organic chemicals in the late 1970s, when I was a PhD student at Stanford University. I had the great good fortune to work with Dr. Perry McCarty on his first big groundwater-contaminants project. It was a very inter-disciplinary project, and I was responsible for understanding the microbiology aspects. This opened the door for me to learn about biochemical transformations, biofilm kinetics, groundwater flow, and transport processes. It was a wonderful foundation for me, and I have continued to learn and to work on groundwater remediation research since then, although I work on many other things in what we now call Environmental Biotechnology. Today, I am the Director of the Biodesign Swette Center for Environmental Biotechnology at Arizona State University. I also am Regents Professor of Environmental Engineering at ASU. I am a member of the U.S. National Academy of Engineering, a Distinguished Member of the American Society of Civil Engineers, a fellow of five professional organizations, and a winner of the 2018 Stockholm Water Prize.

Bruce E. Rittmann

Tempe Arizona, USA, November 2023

Acknowledgments

I deeply appreciate the thorough and useful reviews of and contributions to this book by the following individuals:

- ❖ Dr. Jim Spain, Professor Emeritus, School of Civil and Environmental Engineering, Georgia Tech, USA;
- ❖ Dr. Doug Mackay, Professor Emeritus, Land Air and Water Resources, University of California Davis, Davis, USA;
- ❖ Dr. Lewis Semprini, Distinguished Professor of Environmental Engineering, Oregon State University, USA;
- ❖ Dr. Eric Seagren, Professor of Civil and Environmental Engineering, Michigan Technological University, USA;
- ❖ Dr. Rebecca Parales, Professor, Department of Microbiology and Molecular Genetics, UC Davis, USA;
- ❖ Connie Bryson, Editor, The Groundwater Project, Guelph, Canada;
- ❖ Matthys Dippenaar, Associate Professor, Engineering Geology and Hydrogeology, University of Pretoria, Pretoria, South Africa.

I especially appreciate the contributions of Danilo Amendola, Neto Breda, and Yihao Luo who drafted all of the graphics. I am grateful for Amanda Sills and the Formatting Team of the Groundwater Project for their oversight and copyediting of this book. I thank Eileen Poeter (Colorado School of Mines, Golden, Colorado, USA) for reviewing, editing, and producing this book.

Please note that citations are provided for figures from or adapted from other sources. Any figures without that attribution are GW-Project originals created for this book.

1 Introduction

Organic contaminants are toxic chemicals that pose significant challenges for the health of populations and ecosystems. These compounds have been accumulating at an alarming pace since the dawn of the Industrial Revolution and, subject to winds and currents, often spread widely beyond their point of origin, as well as along the food chain. Because of their toxicity, persistence, and spread, managing the risks associated with organic contaminants is a global issue for which novel actions are needed. Transforming organic contaminants into harmless or less-harmless products is one such approach that has increasingly become the focus of the scientific community.

Microorganisms can often facilitate these transformations. In this book, I discuss what types of transformations can take place to break down harmful substances into less harmful ones and how to assess and create the most favorable environments for optimization of biotic transformation of organic contaminants.

2 The Basics of Microbial Metabolism

Microorganisms can transform organic contaminants into harmless or less-hazardous products. When actively managed, the transformation processes are called *bioremediation* or *engineered bioremediation*. Figure 1 illustrates an example where microbial metabolism can be used. It is a reactive barrier created by stimulating the growth and metabolism of bacteria able to biodegrade a soluble contaminant coming from upstream. The transformation processes can also occur naturally in groundwater, and this is a key part of *natural attenuation* at a contamination site. Whether or not the processes are engineered, they happen only when the correct microorganisms are present and have all the conditions they need to grow, sustain themselves, and carry out the transformation processes of interest.

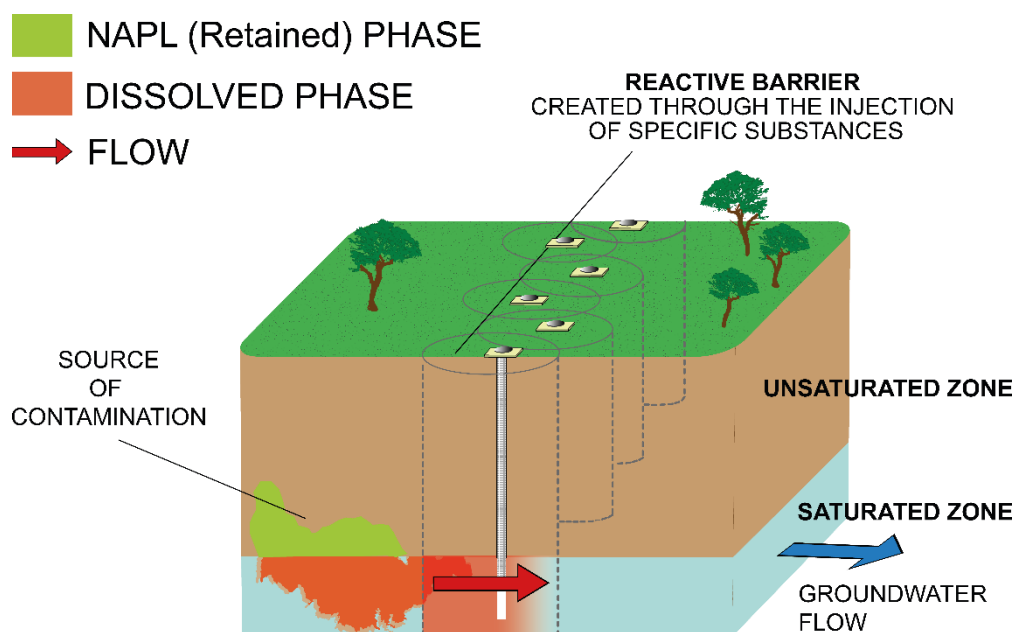

Figure 1 – An example of an engineered bioremediation method for underground/groundwater decontamination when the contaminant's source is a Non-Aqueous Phase Liquid (NAPL). Microbial growth and metabolism are stimulated by addition of specific substances that the bacteria require, which creates a permeable reactive barrier. The biodegradation occurs as dissolved contaminants move with the water through the permeable reactive barrier.

The primary objective of this book is to provide a foundation for understanding three inter-related factors.

1. How microorganisms grow and sustain themselves.
2. How important classes of organic contaminants can be microbially transformed.
3. The conditions necessary so that factors 1 and 2 take place, that is, the correct microorganisms are present, sustained, and active in metabolic processes that transform organic contaminants into harmless products.

This section addresses the first factor: how microorganisms grow and sustain themselves. This is called their *metabolism*. Although the principles of metabolism are the

same for all organisms, the focus here is on bacteria because they are responsible for almost all of the important microbial transformation processes in groundwater. More information on bacteria and the principles of their metabolism can be found in Chapters 2, 3, 5, and 6 of Rittmann and McCarty (2020), along with Madigan and others (2019), Ferris and others (2021), and Wackett and Robinson (2020).

2.1 Electron Donors and Acceptors

In a certain way, bacteria are the same as humans. Both need to “eat and breathe” in order to grow and sustain themselves. All of us are familiar with the food we eat and the oxygen (O₂) we breathe from the air. Bacteria do essentially the same thing, but we give the food and air different names: electron-donor substrate (food) and electron-acceptor substrate (O₂). The term *substrate* means that the bacteria utilize them to gain energy to grow and maintain themselves. The *electron-donor substrate* is a source of electrons, which means that it is oxidized to release electrons. The *electron-acceptor substrate* receives those electrons, which means it is reduced. An electron-donor + electron-acceptor pair works for the bacteria (and us, too) when the transfer of the electrons from the donor to the acceptor generates energy that the bacteria can harvest in a usable form. Because humans are large and complex, we can use only donor + acceptor pairs that generate a large amount of energy for each electron that moves from the donor to the acceptor. A good example shown in Equation (1) occurs when the donor is a carbohydrate (think: pizza or a candy bar) and the acceptor is O₂, (think: breathing).

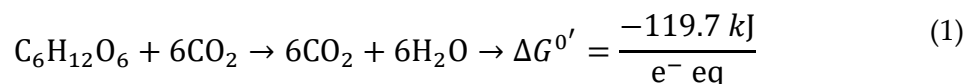

where:

$\Delta G^{0'}$ = the standard free energy of the reaction at pH = 7 and normalized to one electron equivalent (e⁻ eq)

One mole of carbohydrate (C₆H₁₂O₆) is completely oxidized to 6CO₂, which releases 24 e⁻ eq that are transferred to 6O₂, reducing the O in O₂ to the O in CO₂ and H₂O.

Provided the opportunity, many bacteria will gladly perform the same reaction, because the energy yield ($\Delta G^{0'} = -119.7 \text{ kJ}/(\text{e}^- \text{ eq})$) is very large. However, bacteria are not limited to only reactions that generate a large $\Delta G^{0'}$ because they are small and simple. In other words, bacteria have *low overhead*, which means they can grow and sustain themselves when the donor + acceptor pair generates much smaller $\Delta G^{0'}$. When the focus is on transforming organic contaminants, the big difference in energy yield comes from the electron-acceptor substrate (Table 1).

Table 1 - List of $\Delta G^{0'}$ values with carbohydrate being the donor, but with a range of acceptors that bacteria or other prokaryotic microorganisms are able to utilize.

Electron Acceptor and Reduced Product	$\Delta G^{0'}$ kJ/e ⁻⁰ eq
Oxygen (O ₂) to H ₂ O	-119.7
Ferric Iron (Fe ³⁺) to Ferrous Iron (Fe ²⁺)	-115.2
Nitrate (NO ₃ ⁻) to Dinitrogen Gas (N ₂)	-113.2
Selenate (SeO ₄ ²⁻) to Elemental Se ⁰	-72.6
Sulfate (SO ₄ ²⁻) to H ₂ S	-20.1
Carbon Dioxide (CO ₂) to Methane (CH ₄)	-17.4

Although the energy yields for ferric iron (Fe³⁺) and nitrate are almost as large as for O₂, they are much lower for sulfate and carbon dioxide. Despite the paltry energy yields from sulfate and CO₂, many prokaryotic microorganisms can grow using them as their electron-acceptor substrate because the microorganisms are small, simple, and low-overhead.

[Exercise 1](#) ↓ provides an opportunity to calculate the $\Delta G^{0'}$ values when acetate is oxidized, using the acceptors listed in Table 1. [Exercise 2](#) ↓ provides an opportunity to calculate $\Delta G^{0'}$ when toluene is oxidized, using the same acceptors.

2.2 Biomass Synthesis

Most of the energy generated by sending electrons from the donor to the acceptor is used to synthesize new biomass, which we can represent simply as C₅H₇O₂N. The key elements in biomass are carbon (C) and nitrogen (N). C comprises approximately 50 percent of the dry weight of the biomass, and it contains around 71 percent of the electrons of the cells electron equivalents. N is about 12.5 percent of the dry weight and has about 29 percent of the cell's electron equivalents. Thus, C and N constitute major demands for electron equivalents that come from the electron-donor substrate and, in some cases, the N source. The electrons in an electron-donor substrate are partitioned between energy generation (transfer to the electron-acceptor substrate) and investment in new biomass. An electron that is used in synthesis cannot be used to generate energy and vice versa.

Biomass is primarily made up of polymers such as polysaccharides, proteins, nucleic acids, and lipid bilayers. Constructing and maintaining these polymers is an energy expense for the cells. Furthermore, the basic building blocks (e.g., carbohydrates, amino acids, nucleotides, and fatty acids) must be produced from a cell's source of C and N; this is typically another energy-demanding step. All this means that biomass synthesis costs energy in three ways:

1. diverting electrons away from the electron-acceptor substrate,
2. making the basic building blocks from available sources of C and N, and
3. assembling the complex polymers.

The cells balance all the energy and electron flows. A quantitative method to balance those flows and estimate how much biomass can be synthesized from a donor + acceptor pair is the subject of Chapter 5 in Rittmann and McCarty (2020). The “normal” formula for biomass is $C_5H_7O_2N$. When the phosphorus (P) content is included, the formula is expressed as $C_5H_7O_2NP_x$. [Exercise 3](#) provides an opportunity to practice determining the formula weight of $C_5H_7O_2NP_x$ and the value of x .

2.3 Carriers of Electrons and Energy

Electrons and energy do not freely “float around” inside bacterial cells. Instead, they are held on carriers that allow the cells to put the electrons and energy to good use where they are needed. The carrier for energy is ATP, which is short for *adenosine triphosphate*. It holds the energy in the high-energy bond of the third phosphate, which releases the energy when it is hydrolyzed away to form *adenosine diphosphate* (ADP). The ATP can move around in the cell to be used on an as-needed basis.

Electrons are carried in two distinctly different ways. The first carrier is *nicotinamide dinucleotide* (NAD). The oxidized form of NAD is the cation NAD^+ , and it can accept two electrons ($2e^-$) plus two protons ($2H^+$) to make $NADH + H^+$. Similar to ATP, NADH can move about the cell and donate its two electrons for reactions that require them. Likewise, NAD^+ can move about the cell to accept electrons from oxidation reactions. Having these mobile molecules is very important for transformations of organic contaminants, as illustrated in later sections of this book.

The second type of carrier is not mobile—it is anchored in a cell’s membrane. This carrier is an electron-transport chain that operates much like a “bucket brigade” used to fight fires in the past. A series of molecules are precisely located in the membrane so that one molecule “hands off” an electron to the next molecule (Madigan et al., 2019; Rittmann & McCarty, 2020). These molecules are electro-active molecules such as cytochromes and quinones. Electrons and protons are initially fed into the electron-transport chain from NADH or by direct oxidation of a donor substrate. They move down the chain until they reach a terminal electron acceptor such as O_2 , NO_3^- , or other acceptors noted in Section 2.1 and exemplified in Equation (2) and Equation (3).

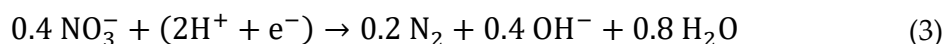
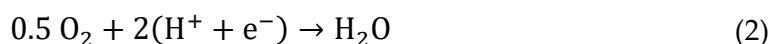

At certain points in the chain, the protons are exported to the outside of the membrane, where they accumulate to create a pH gradient between the exterior and interior of the membrane. This pH gradient creates a free-energy gradient called the *proton motive force* (PMF); the import of protons along this PMF provides the energy to make ATP out of ADP and a phosphate ion. Thus, the flow of electrons ultimately generates the flow of energy in ATP ([Exercise 4](#)).

2.4 Normal Catabolic Reactions

Catabolism is the set of reactions that organisms use to gain energy to grow and sustain themselves. The beginning and end of catabolism are the electron-donor and electron-acceptor substrates. What is important to understand is that these two substrates do not react directly with each other. Instead, the donor is stepwise oxidized, typically two electrons per step. The electrons are carried on NADH and along the electron-transport chain until they reach the electron-acceptor substrate, which is often stepwise reduced (Figure 2). Because the donor is stepwise oxidized, its full oxidation requires a series of oxidation steps that yield characteristic products that become the reactants in the next steps. The same is true for the steps of reducing the electron acceptor. Here, I focus on the normal steps of oxidizing organic electron donors.

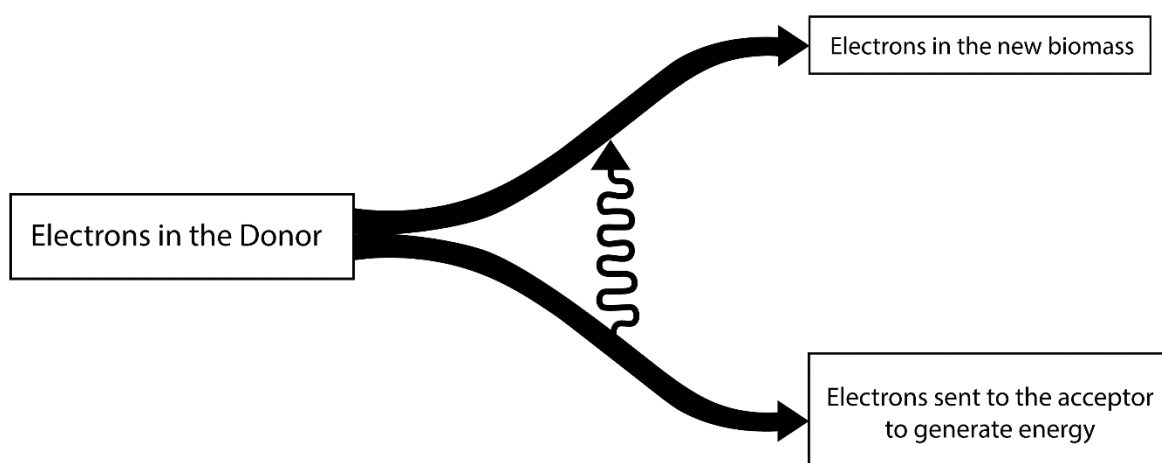

Figure 2 – The electrons from the bacteria’s electron donor are partitioned between synthesis of new biomass and transfer to the electron acceptor to gain energy.

Two reasons explain why it is essential to understand the normal steps of electron-donor oxidation. First, these are the steps necessary for the microorganisms to gain electrons and energy to grow and sustain themselves. Microorganisms will not be present if these steps do not occur. Second, the biodegradation of organic contaminants involves the same reactions, although other reactions may be necessary in some situations.

It is valuable to understand where and how the biodegradation of organic contaminants fits into normal catabolism. When it fits, the microorganisms are able to gain electrons and energy as part of the biodegradation of the contaminants. In that case, biotransformation of the contaminant supports synthesis of the biomass that biodegrades it. We then call the organic contaminant a *primary substrate*. A primary substrate generates the flow of electrons and energy that enable biomass growth (Figure 3).

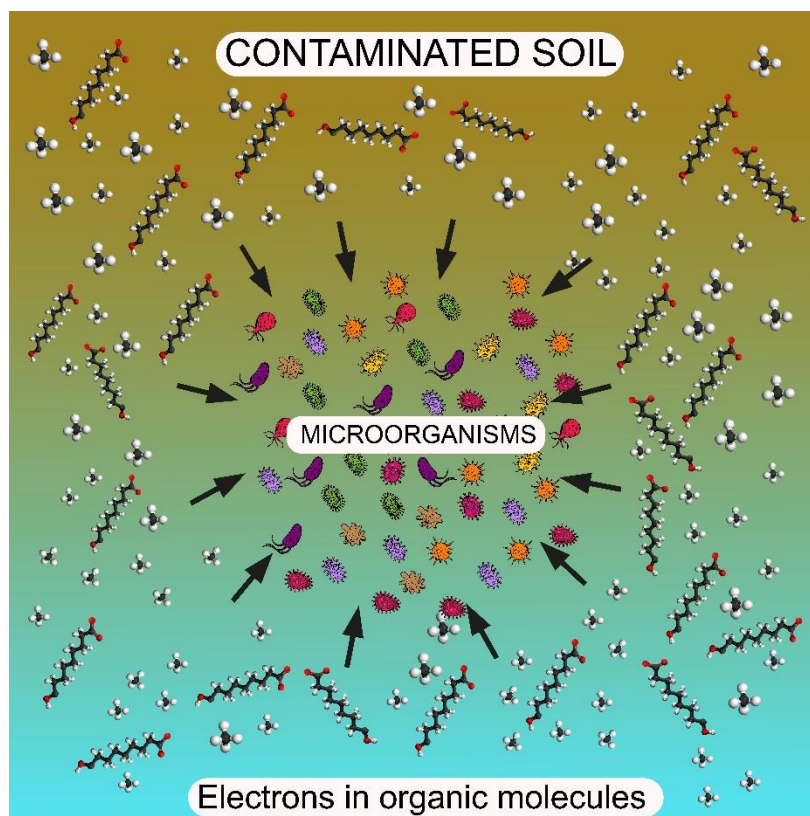

Figure 3 – Microorganisms interacting with the environment to receive electrons to sustain their growth as part of the biodegradation of the contaminants.

2.4.1 Hydroxylation and Dehydrogenation

The core reactions for the stepwise oxidation of organic electron donors are called *hydroxylation* and *dehydrogenation*, which—like all metabolic reactions—are catalyzed by enzymes. Both are two-electron oxidation of the reacting organic molecule, which means that they yield $2(\text{H}^+ + \text{e}^-)$, which are used to reduce NADH^+ to $\text{NADH} + \text{H}^+$. The difference is that hydroxylation includes H_2O as a reactant, which produces an oxidized product containing a new hydroxyl group ($-\text{OH}$); in contrast, dehydrogenation does not use H_2O or add $-\text{OH}$. Figure 4 shows examples of basic hydroxylation and dehydrogenation reactions for ethanol ($\text{CH}_3\text{CH}_2\text{OH}$). The figure contains three essential take-home lessons.

1. Both reactions remove two electrons from the organic reactant and transfer them to NAD^+ ; thus, oxidation from ethanol to acetic acid generates four e^- equivalents.
2. The dehydrogenation and hydroxylation reactions alternate, which is the typical pattern.
3. The end-product is acetic acid, which is an exceptionally important organic component inside microbial cells. What the cells do with acetic acid is described in an upcoming section in this book.

[Exercise 5](#) and [Exercise 6](#) provide opportunities to explore hydroxylation and dehydrogenation reactions.

Dehydrogenation of ethanol to acetaldehyde

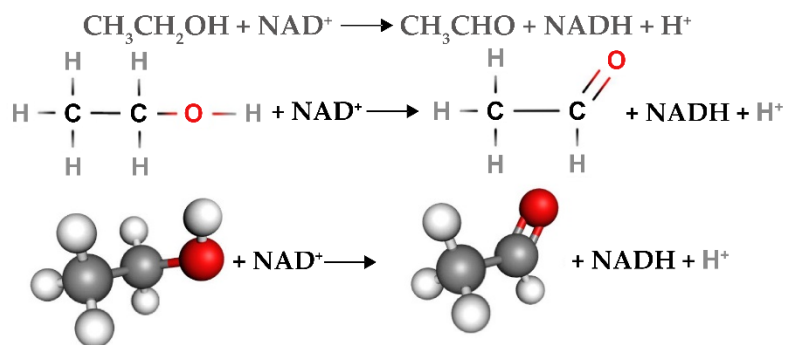

Hydroxylation of acetaldehyde to acetic acid

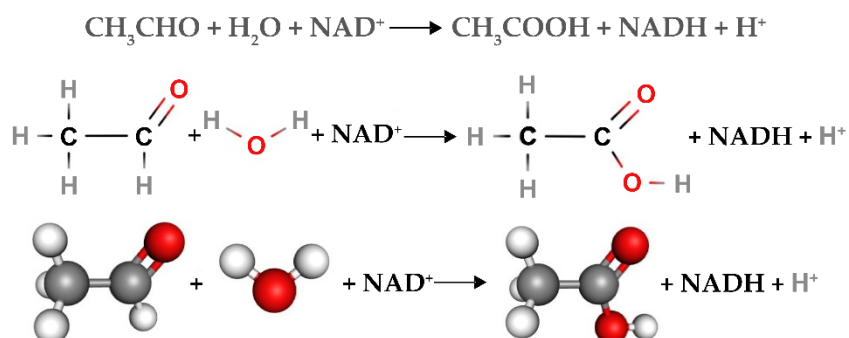

Figure 4 – The dehydrogenation and hydroxylation reactions that convert ethanol to acetate: dehydrogenation of ethanol to acetaldehyde and hydroxylation of acetaldehyde to acetic acid. In both cases, NAD^+ receives two electrons and is reduced to NADH . Oxygen atoms are red.

2.4.2 β -Oxidation

In Figure 4, the dehydrogenation and hydroxylation reactions occur with molecules that contain two carbon atoms (i.e., ethanol and acetaldehyde). What if the organic molecule has more than two carbon atoms? The microbial strategy for longer chains is to break the longer compounds into a series of acetic acids. The strategy is called *beta* (β) *oxidation*, because the β carbon (i.e., the second C from after the carboxylate group) is stepwise oxidized until it can become a carboxylate group with acetic acid released.

Figure 5 illustrates the steps of β -oxidation which also uses alternating dehydrogenation and hydroxylation reactions that stepwise oxidize the β carbon. Hydration and hydrolysis steps also are involved, but the key steps are the two oxidations of the β carbon, which release four e^- equivalents along with one acetic acid. The electrons can be routed to the electron transport chain for energy generation, and the acetic acid can be routed to the citric acid cycle, which is the topic of the next section of this book. [Exercise 7](#) provides an opportunity to explore β -oxidation.

Dehydrogenation

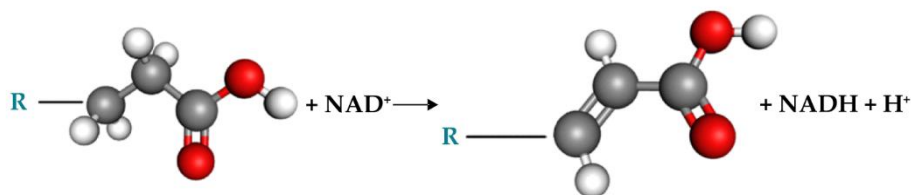

Hydration

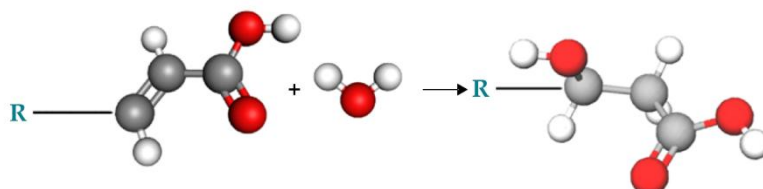

Dehydrogenation

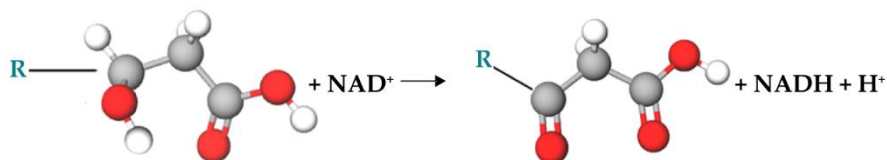

Hydrolytic Cleavage

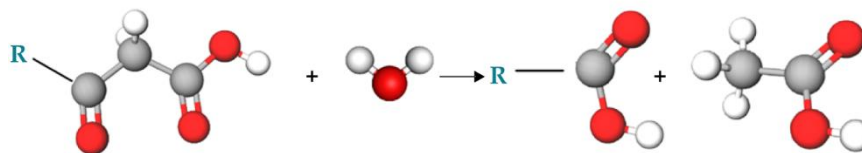

Figure 5 – Illustration of how β -oxidation stepwise oxidizes the β carbon (the C next to COOH) until it becomes a carboxylate group, with acetic acid (CH_3COOH) released by hydrolytic cleavage. R represents an organic group (e.g., a C chain or aromatic) attached to the β carbon; it is not altered by a round of β oxidation. Oxygen atoms are red.

2.4.3 The Citric Acid Cycle

Alternating dehydrogenation and hydroxylation reactions generate acetic acid as shown in Figure 4 and Figure 5. Acetic acid is exceptionally useful within a microbial cell. The main vehicle by which the microorganisms utilize acetic acid is the *Citric Acid Cycle*. Figure 6 is a simplified version of the citric acid cycle, which gains its name from the step in which a molecule of acetic acid (two carbons) is combined with a molecule of oxaloacetic acid (four carbons) to form citric acid (six carbons). The cycle involves a sequence of reactions that include two dehydrogenations and two hydroxylations that recover the eight e^- equivalents in acetic acid, release two CO_2 molecules, and return oxaloacetic acid

to begin another round of the cycle. The overall reaction for one turn of the citric acid cycle is shown in Equation (4) and Figure 6.

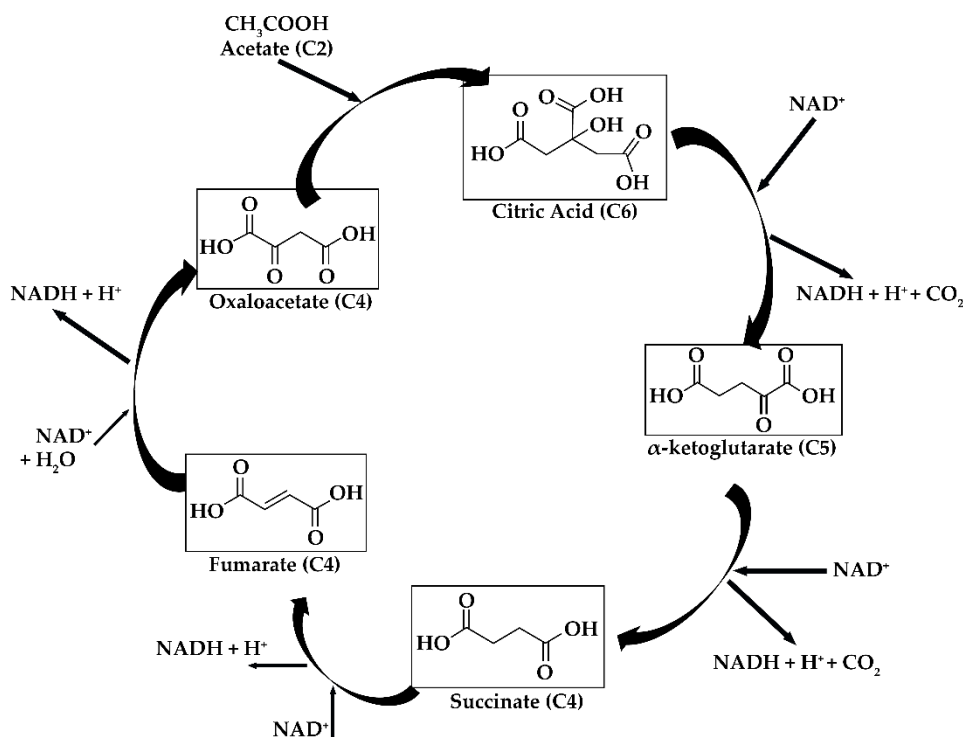
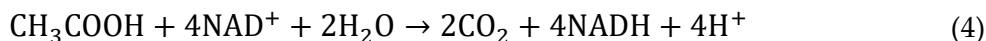

Figure 6 – A simplified version of the citric acid cycle, emphasizing the input of acetate, the release of two CO_2 molecules, and the four oxidation steps. Citric acid enters the cycle bound to the carrier coenzyme A (CoA), which is not illustrated here for simplicity.

Besides generating electron flow, the citric acid cycle is valuable to the microorganisms in another way. The six- and five-carbon intermediates (sometimes denoted as C6 and C5) can be used in synthesis that requires organic molecules with more than two carbon atoms. Diverting the six- and five-carbon compounds out of the cycle costs electron flow and energy, but it is an efficient way to take acetic acid—the simple product of many catabolic reaction pathways—into the more complex organic molecules needed to make the polymers that comprise most of biomass [Exercise 8](#)↓.

3 Biodegradation of Organic Contaminants

The range of organic contaminants found in groundwater is immense because our modern society produces and consumes organic chemicals for almost every facet of human life: energy, agriculture, the chemical and pharmaceutical industries, cleaning, the military, and more. Some of these chemicals are released to the environment during their manufacture, distribution, use, and disposal. Many reach the groundwater and present acute or chronic risks to human and ecosystem health. Ideally, the contaminants can be biodegraded to harmless forms naturally or through engineered bioremediation.

While some common organic contaminants can be biodegraded through the normal catabolic processes summarized above, others require special considerations. It is important to determine when biodegradation can proceed normally versus when something special is needed. Special steps are needed in situations such as the following:

- the chemical structure of the molecule needs to be modified before the usual dehydrogenation and hydroxylation reactions can begin;
- the transformation of the contaminant cannot support the growth of the bacteria because it does not yield enough (or any) electron flow to generate ATP;
- the compound is not accessible by the bacteria; and
- the compound needs to be reduced, not oxidized.

This section provides background for determining why and when special considerations are necessary. Sections 4 through 9 summarize information about the biodegradability of common organic contaminants. More detailed information can be found in Chapters 3, 5, and B2 of Rittmann and McCarty (2020). Context about how all the information can be applied to bioremediation can be found in National Research Council (NRC; 1993), NRC (2000), Moyer and KostECKI (2003), and Rittmann and others (1994). All reactions are catalyzed by enzymes, and an excellent review of relevant enzymes is provided by Wackett and others (2020). Another valuable resource for details about metabolic pathways and enzymes is the EAWAG Biocatalysis/Biodegradation Database (<http://eawag-bbd.ethz.ch/>[↗]).

3.1 Activation by Mono- and Di-oxygenations

Hydrogenation and hydroxylation reactions proceed with organic molecules that already have at least one O-containing group, such as –OH for an alcohol or –COOH for a carboxylic acid. If an O-containing group is absent, the first step is to insert –OH into the molecule. Bacteria are able to do this via *mono-oxygenation* and *di-oxygenation* reactions. Figure 7 presents examples of each.

Methane mono-oxygenation**Toluene mono-oxygenation****Dioxygenation of benzene to catechol****Dioxygenation of catechol with Ring Cleavage**

Figure 7 – Examples of mono-oxygenation and di-oxygenation reactions. Ph stands for the phenolic group ($-\text{C}_6\text{H}_4\text{OH}$). Oxygen atoms are red.

Mono-oxygenation and di-oxygenation reactions have three common features.

1. Molecular oxygen (O_2) is needed as a direct reactant. This O_2 is not used as an electron-acceptor substrate, and its reduction does not generate ATP. However, it means that O_2 must be present.
2. Both reactions replace $-\text{H}$ with $-\text{OH}$; mono-oxygenations insert one $-\text{OH}$ group, and di-oxygenations insert two $-\text{OH}$ groups. These insertions of one or two $-\text{OH}$ groups lead the names *mono*-oxygenation and *di*-oxygenation, respectively, and the C is oxidized by two e^- equivalents for each $-\text{OH}$ group.
3. The overall mono-oxygenation reaction and the first step of di-oxygenation consume NADH, although the NADH is regenerated in the second step of the di-oxygenation. Even though C is oxidized in both cases, mono-oxygenation is a net consumer of electron equivalents (the NADH), and di-oxygenation is net

neutral with regard to electron equivalents. Thus, the two oxygenation reactions are examples of *activation* reactions that do not provide a direct gain of electrons and energy to the bacteria but open up the possibility of downstream dehydrogenations and hydroxylations. [Exercise 9](#) provides practice with mono-oxygenation, and [Exercise 10](#) provides an opportunity to consider di-oxygenation.

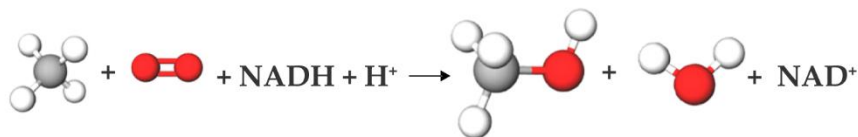
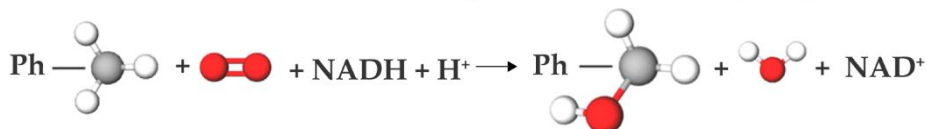
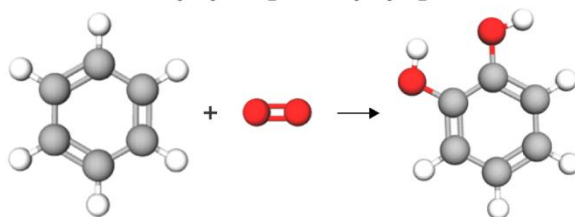
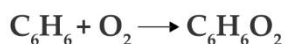
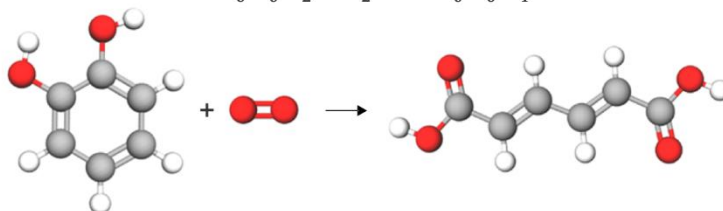
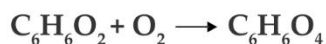
3.2 S_{min} , Secondary Utilization, and Co-metabolism

The rate at which catabolism produces energy has to be great enough to at least meet the cells' minimum needs for their own maintenance demands. Because the rate of electron-donor substrate utilization depends on the substrate's concentration, a very low substrate concentration may not provide sufficient energy flow to keep the bacteria alive and active over the long-term. This concept can be represented quantitatively by S_{min} , the minimum substrate concentration able to sustain biomass at steady state. S_{min} can be computed as shown in Equation (5). Chapter 6 in Rittmann and McCarty (2020) provides guidance for estimating the values of K_s , b , Y , and q_{max} .

$$S_{min} = \frac{K_s b}{(Y q_{max}) - b} \quad (5)$$

where:

S_{min} = minimum substrate concentration able to sustain biomass at steady state (ML⁻³)

K_s = substrate concentration when reaction rate is half the maximum rate (ML⁻³)

b = endogenous decay rate representing the growth rate required to maintain biomass at steady state (T⁻¹)

Y = true yield, i.e., biomass generated per mass of substrate utilized (dimensionless)

q_{max} = maximum rate of substrate utilization, biomass created per mass of substrate utilized per unit time (MsMx⁻¹T⁻¹)

When the groundwater concentration of an organic contaminant is greater than its S_{min} , its biodegradation can sustain the bacteria that biodegrade it. However, the concentration of organic contaminants that create health or environmental risks are often low (e.g., µg/L) compared to S_{min} values. In that case, biodegradation of the contaminant cannot support the biomass needed to biodegrade the contaminant. However, biodegradation of the contaminant is possible when the same bacteria are able to utilize several organic compounds simultaneously such that the combined electron and energy flows are enough to sustain biomass growth and maintenance. This situation is termed secondary utilization, which means that the biodegradation of one substrate is enabled by the simultaneous utilization of another, or many other, substrates. Secondary utilization

focuses attention on other organic compounds in the groundwater, not solely on the target contaminant. An opportunity to practice calculating S_{min} is provided in [Exercise 11](#) ↓.

Another concept important to determining why and when special considerations are necessary is *co-metabolism*, which occurs when an enzyme that targets the transformation of a particular substrate accidentally transforms another substrate. While this may be advantageous in terms of detoxifying the co-metabolic substrate, it does not benefit the cells. This is because the co-metabolic product is not transformed further such as by dehydrogenation and hydroxylation reactions. Quantitatively, Y is zero for a co-metabolic compound. This means that co-metabolism relies on having other substrates present to grow the biomass and usually to induce expression of the key enzyme (Figure 8).

Epoxidation of trichloroethylene (TCE) by methane mono oxygenase (MMO)

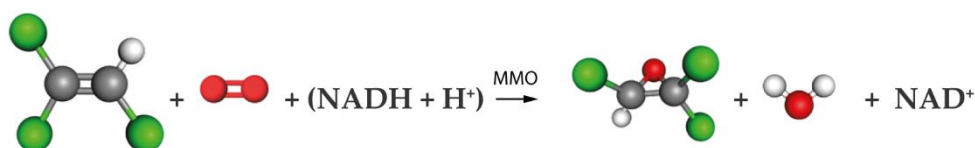
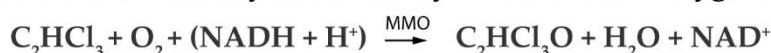

Oxidation of ethyl benzene to phenylacetic acid

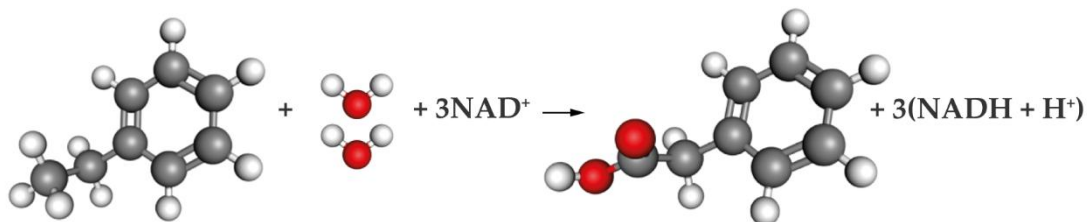

Figure 8— Examples of co-metabolism: epoxidation of TCE (trichloroethene) by methane mono-oxygenase (MMO) to form trichloroacetyloxy; and oxidation of ethyl benzene to phenylacetic acid. Oxygen atoms are red and chlorine atoms are green.

3.3 Hydrophobicity and Bioavailability

Many organic contaminants found in groundwater are *hydrophobic*, which means that they have low water solubility; in other words, they “hate” to dissolve in water. Instead of dissolving in water, these hydrophobic molecules either adsorb to soil or aquifer solids or form a separate non-aqueous phase liquid (NAPL). The NAPLs can be divided into two types—Light NAPL (LNAPL) or Dense NAPL (DNAPL)—with LNAPLs floating on water while DNAPLs are denser and sink. Different remediation strategies are needed to adequately remove DNAPLs and LNAPLs. Figure 9 shows an example of bioremediation for an LNAPL

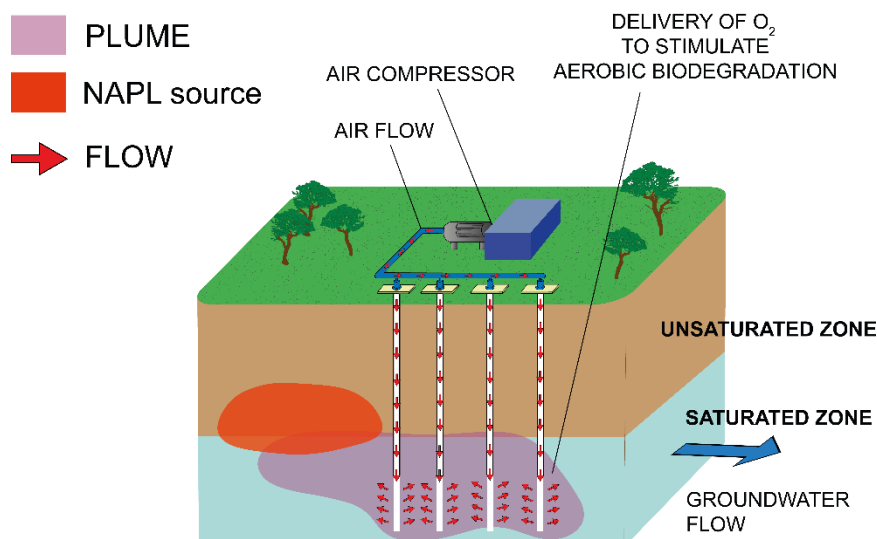

Figure 9 – Biosparging (i.e., injecting pressurized air into a contaminated zone to stimulate in situ aerobic biological activity) as a means of in situ bioremediation of an LNAPL (light non-aqueous phase liquid) such as gasoline.

A molecule's hydrophobicity can be gauged by its octanol-water partition coefficient (K_{ow}) in units of $L_{H_2O}/L_{octanol}$. A value of K_{ow} that is greater than $10 L_{H_2O}/L_{octanol}$ indicates significant hydrophobicity; strongly hydrophobic organics have K_{ow} values greater than $10^4 L_{H_2O}/L_{octanol}$. Most of a hydrophobic-contaminant's mass is adsorbed on the mineral matrix or resides as free product in the NAPL source, not in the water ([Exercise 12](#))¹.

Bacteria are able to utilize only the organic molecules dissolved in the water; this is known as being *bioavailable* to the bacteria. Low water solubility means that the concentration of bioavailable organic contaminant in the groundwater is always low. This can lead to an S_{min} limitation that would preclude accumulating enough biomass unless the bacteria are able to utilize several substrates simultaneously.

The dissolution of hydrophobic compounds to the groundwater is usually slow, meaning the large mass of sorbed or NAPL-bound contaminants is a long-term source of groundwater contamination. Thus, in situ bioremediation is usually a process requiring many years, or even decades, to complete.

3.4 Some Compounds Need to be Reduced

The discussion so far in this book has looked at organic compounds as electron-donor substrates: that is, compounds that are biodegraded via oxidation reactions such as dehydrogenations, hydroxylations, and mono- or di-oxygenations. However, some of the most troublesome organic contaminants in groundwater contain oxidized substituents that cause their carbon to be oxidized. Those substituents include halogens (particularly Cl and F) and oxidized nitrogen groups (particularly nitro- and nitroso-groups). Because the carbon is oxidized, the organic contaminant can become an

electron acceptor as long as materials are present that can serve as electron-donor substrates. Examples of electron-donor substrates are given in Sections 6 to 9 of this book.

It is essential to distinguish if the organic contaminant of interest needs to be oxidized or reduced. If it is to be oxidized, then an electron acceptor must be supplied (naturally or by engineered means) at a rate sufficient to complete the oxidation of the donor substrate. If the organic contaminant is an electron acceptor, an electron donor must be supplied at a sufficient rate. Misunderstanding what needs to be supplied will completely subvert any chances for a successful bioremediation! Figure 10 illustrates how the two scenarios are correctly implemented. [Exercise 13](#) provides an additional opportunity to practice concepts presented in this section.

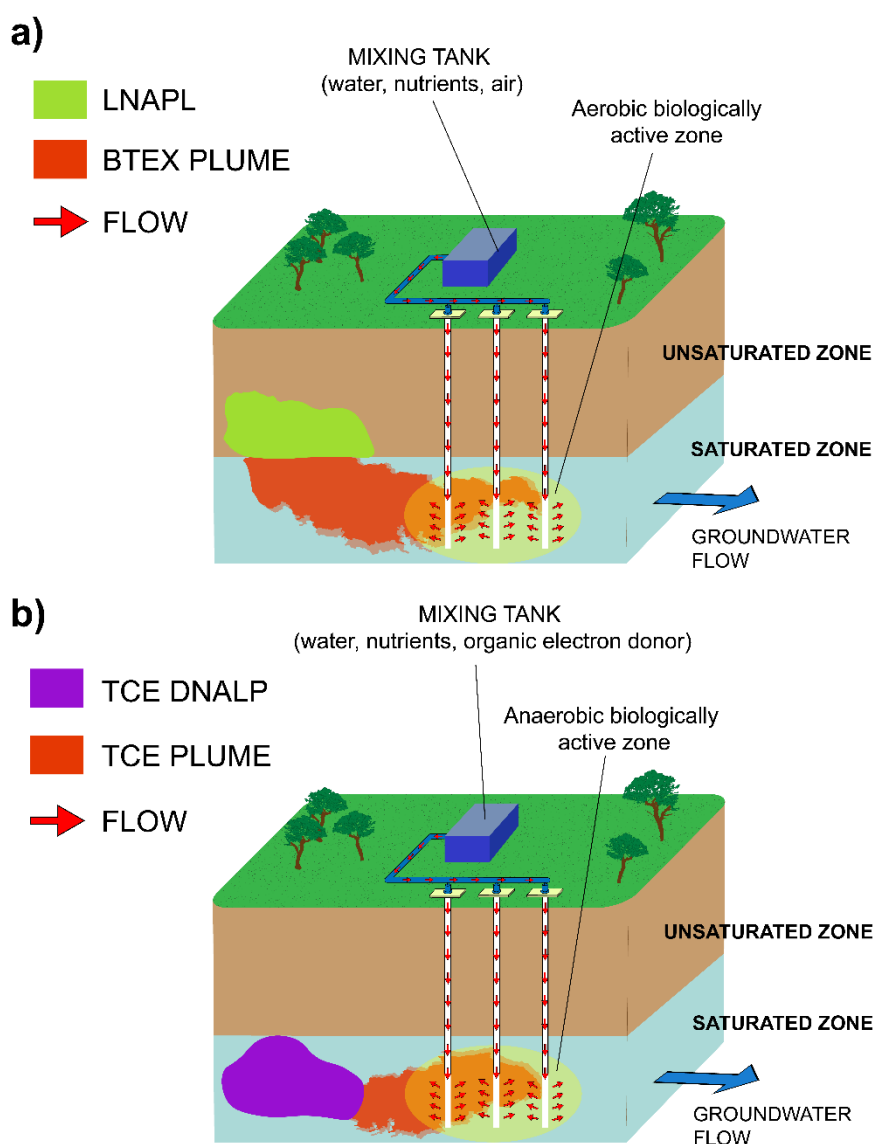

Figure 10 – Examples of supplying the correct substrate to stimulate bioremediation. a) Stimulating aerobic biodegradation of BTEX (benzene, toluene, ethylbenzene, and xylene) in an LNAPL (light non-aqueous phase liquid). b) Stimulated reductive dichlorination of TCE (trichloroethylene) in a DNAPL (dense non-aqueous phase liquid).

4 Hydrocarbons

Hydrocarbons are organic molecules that contain only carbon and hydrogen. Hydrocarbon contamination mainly comes from petroleum and petroleum products. The diversity of chemical structures is nearly infinite since petroleum itself is a mixture of thousands of organic constituents, and products developed from petroleum utilize virtually every chemical in the petroleum feedstock. Hydrocarbons include aliphatic chains (normal and branched), cyclic aliphatics, and aromatics with one or a multitude of rings. Figure 11 illustrates some of the chemical forms of hydrocarbons.

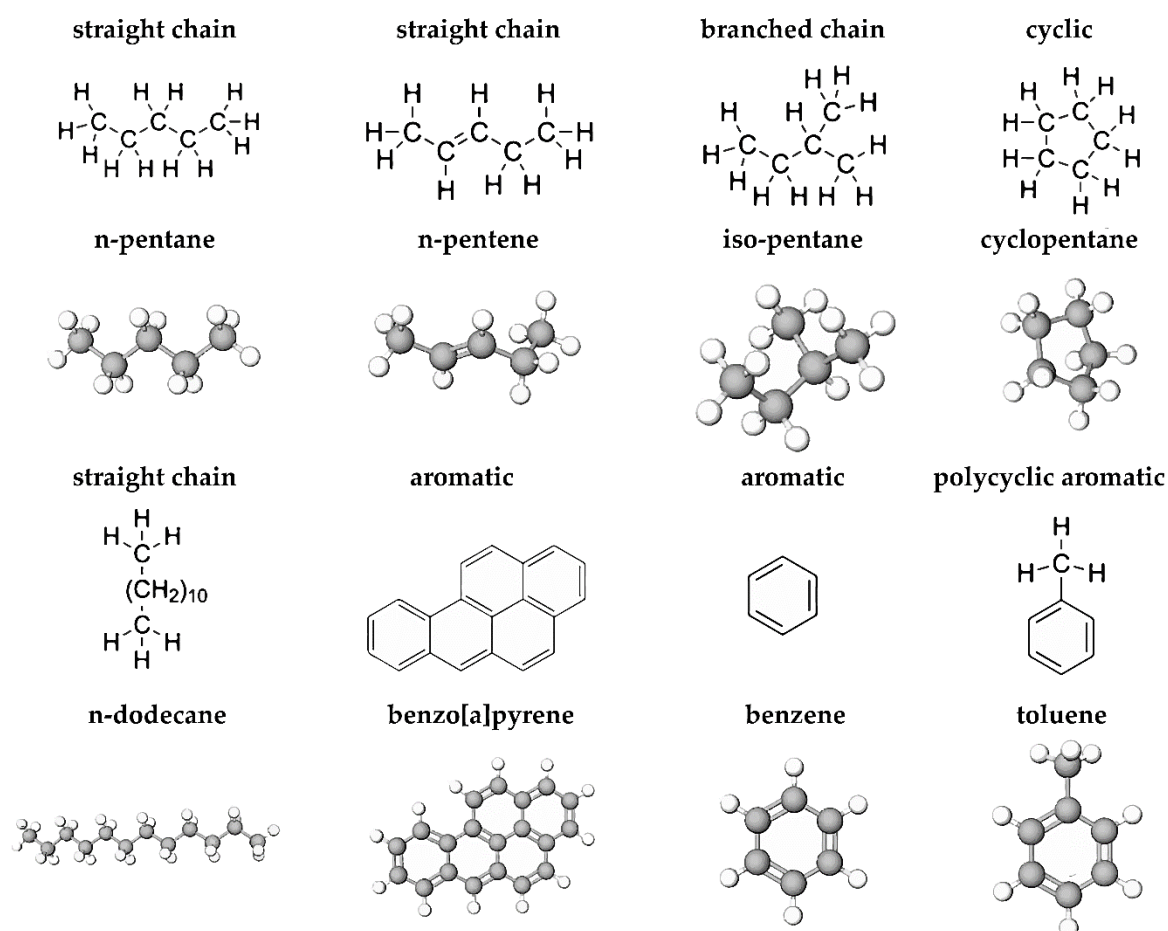

Figure 11 – Characteristic structures of hydrocarbons: straight chains, branched chains, cyclic, aromatic, and a polycyclic aromatic hydrocarbon (PAH). Benzo[a]pyrene is the PAH.

Although the structural diversity of hydrocarbons is immense, all of them are hydrophobic. The hydrophobicity stems directly from the fact that they have no polar substituents like O-containing functional groups. Relatively small hydrocarbons are modestly hydrophobic. For example, K_{ow} values (in $L_{H_2O}/L_{octanol}$) are $10^{2.2}$ for benzene, $10^{2.7}$ for toluene, $10^{3.3}$ for ethyl benzene, $10^{3.0}$ for cyclopentane, and $10^{3.5}$ for n-pentane. However, large molecules have exceptionally large K_{ow} values. For example, K_{ow} values are $10^{4.6}$ for phenanthrene, $10^{6.1}$ for benzo[a]pyrene, and $10^{6.8}$ for n-dodecane.

Hydrophobicity means that aqueous-phase concentrations are very low, often making them bio-unavailable and unable to sustain biomass by their biodegradation alone.

The lack of O-containing functional groups also means that the molecules need to be activated by insertion of O to initiate biodegradation. While some bacteria can activate hydrocarbons anaerobically, by far the most important activation mechanism is via mono- or di-oxygenation. This means that O_2 must be present to begin biodegradation. Figure 12 shows some characteristic mono- and di-oxygenation reactions for hydrocarbon contaminants. Once the hydrocarbons are activated by one or (usually) several oxygenations, they can be oxidized by the usual dehydrogenation, hydroxylation, β -oxidation, and citric-acid-cycle reactions that yield NADH and ATP. In addition, activation makes them much less hydrophobic. For example, the K_{ow} values are $10^{1.5}$ for phenol (benzene with one $-OH$) and for 1-pentanol (n-pentane with one $-OH$) and $10^{0.84}$ for 2-pentanone (n-pentane with one ketone (CO) group).

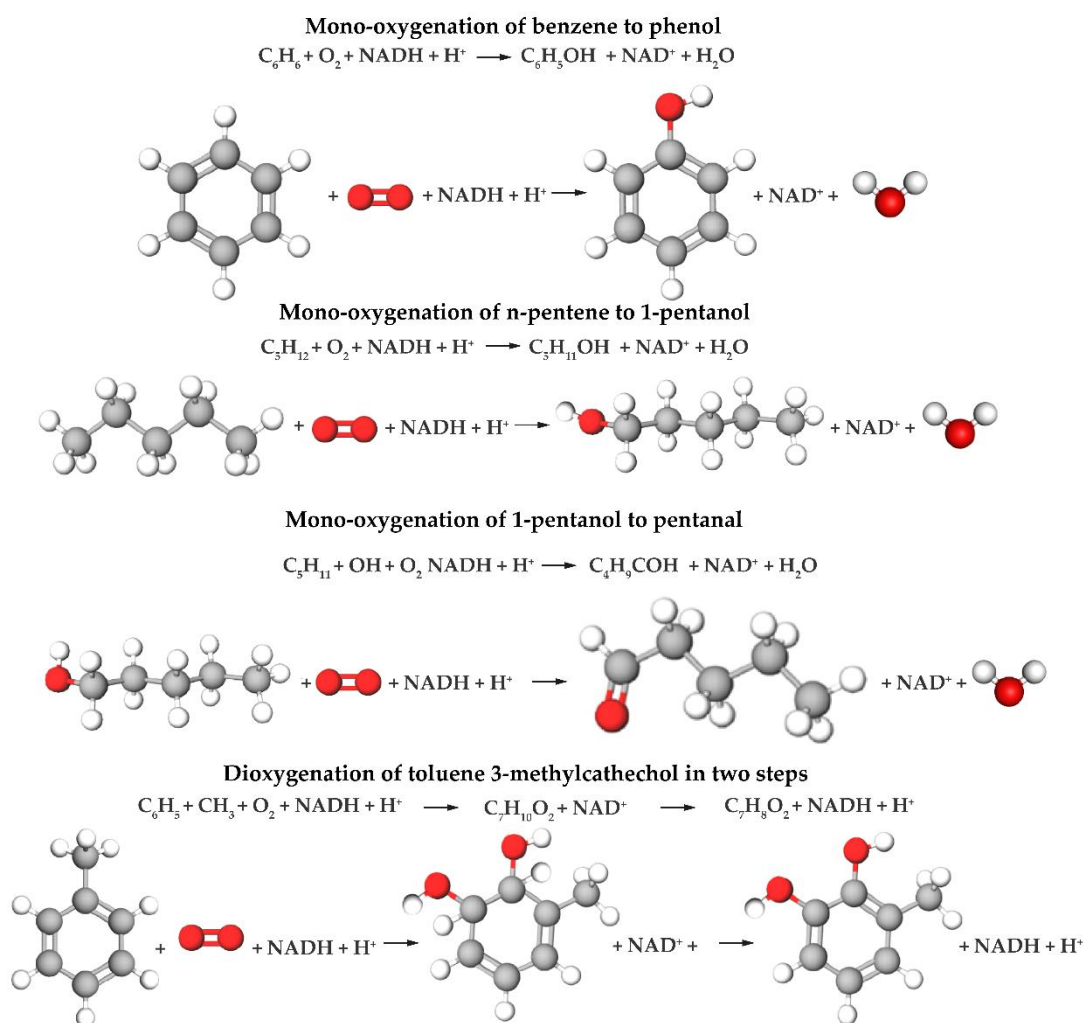

Figure 12 – Examples of activating hydrocarbons by mono- and di-oxygenation. Each $NADH + H^+$ contains two e^- equivalents. Oxygen atoms are red.

A final common characteristic of the hydrocarbons is that their carbons are reduced since the carbons are bonded only to other carbons or to electro-positive H. This means that post-activation biodegradation of the hydrocarbons yields much NADH and ATP per C molecule. For comparison, glucose needs no activation, and its carbon releases $4 e^-$ equivalents per mol C. The electron releases after two activation steps are $3.7 e^-$ eq/mol C for benzene, 4.8 for n-pentane, and 4.1 for pyrene.

In summary, hydrocarbons are excellent electron-donor substrates if they can be activated by mono- or di-oxygenation reactions. Addition of $-OH$ groups (the topic of this section) make the molecules more water soluble. Hydrocarbons retain high contents of electrons and energy, even though the activation steps partially oxidize the molecules.

5 Oxygen-containing Organics of Special Interest

A number of important organic contaminants already contain oxygen within the molecule. This should make them more readily susceptible to biodegradation since the activation step may not be needed; additionally, they are more water-soluble than hydrocarbons. This section reviews several important examples of oxygenated contaminants: phenol, ethanol, MTBE, and 1,4-dioxane.

Phenol (C_6H_5OH) is a benzene ring with one $-OH$ substituent. Phenol can be generated as a mono-oxygenation product of benzene (as was shown in Figure 12), but it is widely found in groundwater from its use in industry to synthesize plastics, herbicides, pharmaceuticals, and epoxies. Phenol biodegradation typically requires one or more oxygenation steps to add another $-OH$ group and cleave the aromatic ring; this is illustrated in Figure 13. Once the ring is opened, the alkene chain can be oxidized by a series of dehydrogenations and hydroxylations. Although a high concentration of phenol can be inhibitory, phenol is readily biodegradable at moderate concentrations when O_2 is available.

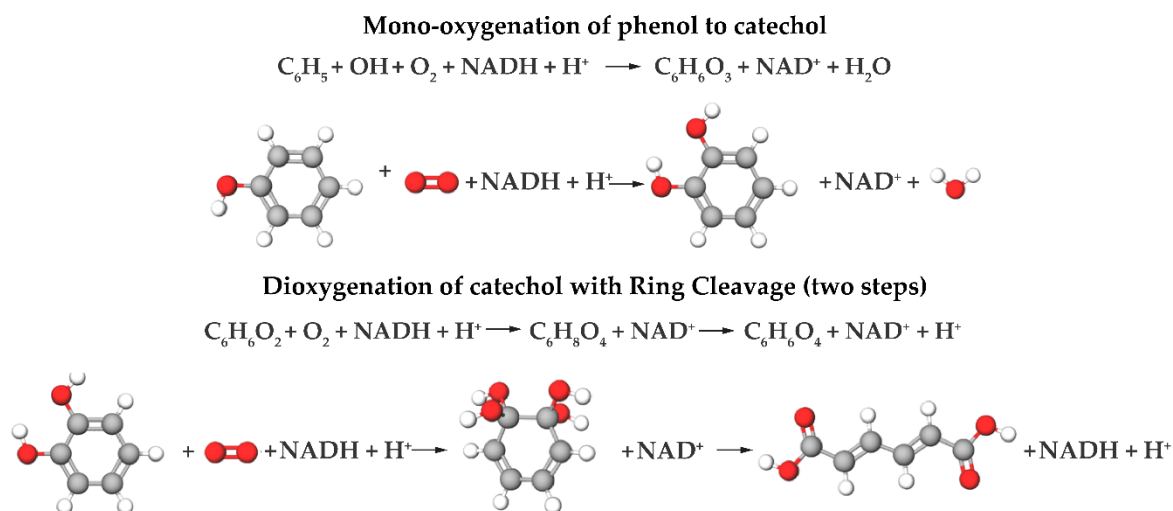

Figure 13 – Typical pathways leading to ring cleavage of phenol. Oxygen atoms are red.

Ethanol (CH_3CH_2OH) is an important groundwater pollutant because it has been added to gasoline as an *oxygenate* to reduce carbon monoxide (CO) and unreacted-hydrocarbon emissions. Unlike the other major organics in gasoline (benzene, ethyl benzene, toluene, and xylene: BTEX), ethanol is not hydrophobic, which means that it dissolves in and moves with the water. Ethanol is readily biodegraded by many bacteria using the mechanisms described in Section 2.4.

MTBE (methyl-*tertiary*-butyl ether, $((CH_3)_3COCH_3$) is another oxygenate added to gasoline to reduce emissions. Similar to ethanol, MTBE is highly water soluble. It also imparts taste and odor to the water and may have health risks. MTBE is biodegradable in aerobic conditions. Two mono-oxygenation reactions are needed to activate the molecule

to 1-methyl-1,2-propane diol, which can be oxidized by typical dehydrogenation and hydroxylation reactions (Moyer et al., 2003; Rittmann & McCarty, 2020). However, unlike ethanol, bacteria able to biodegrade MTBE are not common, which means that natural attenuation cannot be assumed ([Exercise 14](#)↴).

1,4-dioxane ($C_4H_8O_2$) is associated with contamination from chlorinated solvents (as discussed in Section 6) because it is used as a stabilizer. 1,4-dioxane is completely water soluble, which means that it moves with the groundwater ahead of the chlorinated solvents, which are hydrophobic and, thus, their transport is retarded. 1,4-dioxane can be biodegraded by bacteria that possess certain mono-oxygenase enzymes—for example, methane, ethane, propane, and butane mono-oxygenases. Figure 14 illustrates the transformations brought about by mono-oxygenases. The final product (a carboxylate ester triol) should be susceptible to regular dehydrogenation and hydroxylation reactions that lead to energy generation and growth. However, biodegradation of 1,4-dioxane via mono-oxygenation also can be co-metabolic, perhaps because only the first mono-oxygenation occurs. Thus, the bacteria that biodegrade 1,4-dioxane always need its normal substrate (e.g., ethane or propane) to induce expression of the mono-oxygenases, and they may need it as the primary substrate to grow and sustain the biomass ([Exercise 15](#)↴) and ([Exercise 16](#)↴.)

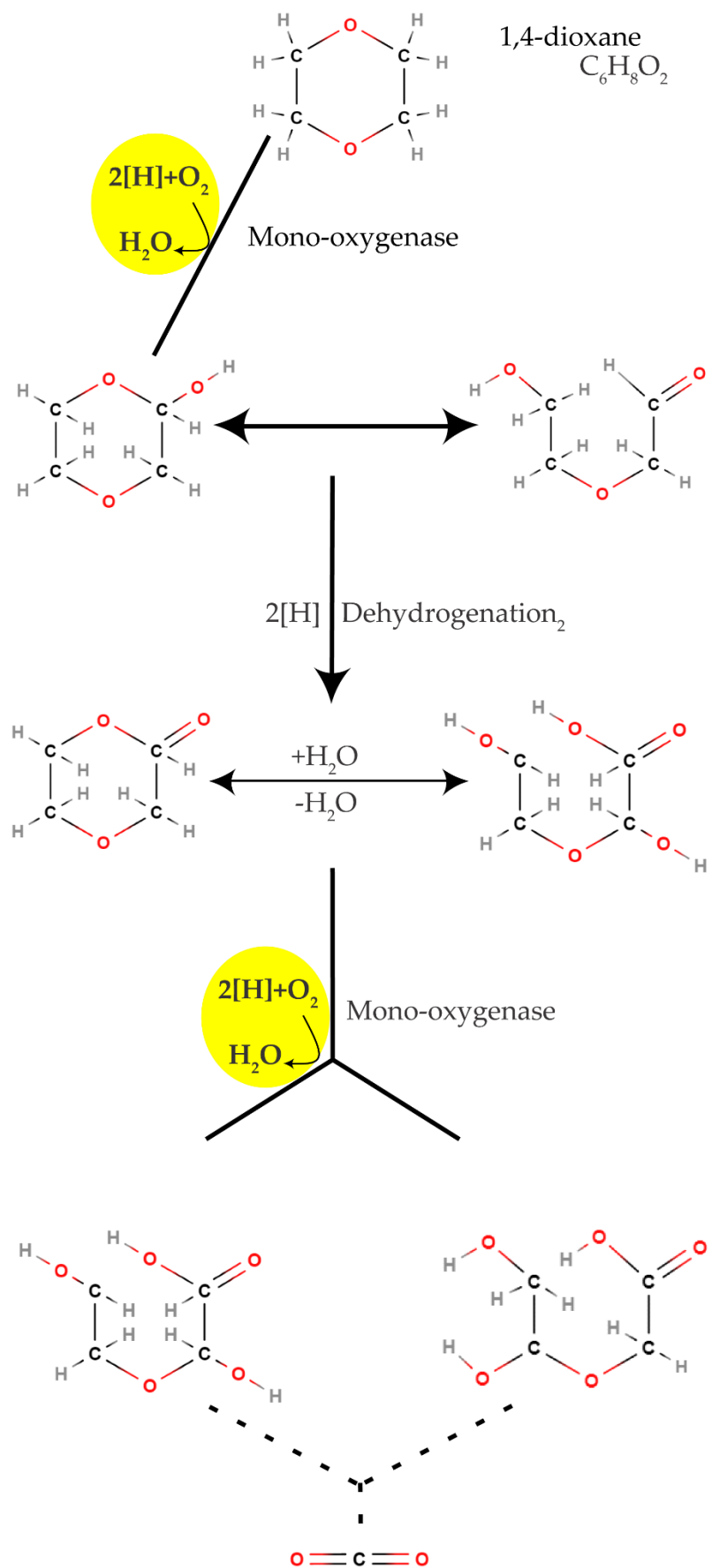

Figure 14 – Examples of two mono-oxygenation reactions (highlighted) that initiate the biodegradation of 1,4-dioxane. Oxygen atoms are red.

6 Chlorinated Alkanes and Alkenes

Among the most common and troublesome of groundwater contaminants are the chlorinated alkanes and alkenes. The two most important ones are trichloroethene (TCE: C_2HCl_3 , which is also called trichloroethylene) and the trichloroethanes (TCA: $C_2H_3Cl_3$, which are widely used as solvents for metals, electronics, and clothes contaminated with oils and grease). Other important chlorinated alkanes and alkenes are carbon tetrachloride (CCl_4), chloroform ($CHCl_3$), dichloromethane (CH_2Cl_2 which is also called methylene chloride), tetrachloroethene, ($C_2H_2Cl_4$, also called perchloroethylene), the dichloroethenes ($C_2H_2Cl_2$), the dichloroethanes ($C_2H_4Cl_2$), vinyl chloride (C_2H_3Cl), and chloroethane (C_2H_5Cl). All are moderately hydrophobic, with K_{ow} values ranging from $10^{0.6}$ (vinyl chloride) to $10^{2.6}$ (carbon tetrachloride).

Especially for the more chlorinated contaminants, the important biodegradation route is *reductive dechlorination*, in which the Cl substituents are stepwise removed and replaced by H. Each step is a two-electron reduction, and the electron donor is typically molecular (H_2). As shown in Figure 15 for TCE and chloroform, reductive dechlorination can proceed until the molecule is fully reduced and dechlorinated ([Exercise 17](#)↓).

a)

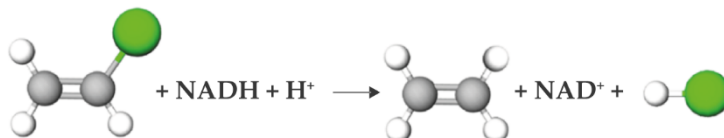
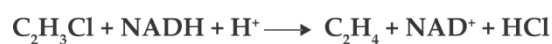
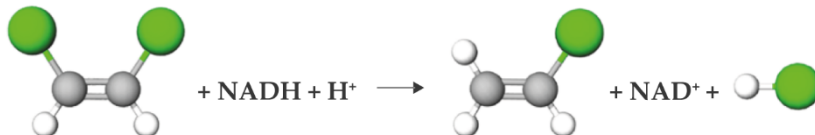
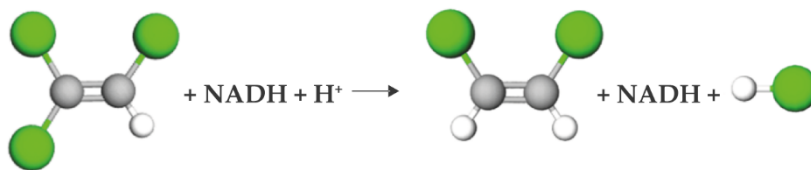
Three-step reductive dechlorination of TCE (C_2HCl_3) to ethene (C_2H_4)

b)

Three-step reductive dechlorination of chloroform ($CHCl_3$) to methane (CH_4)

Figure 15 – Stepwise reductive dechlorination of a) TCE and b) chloroform. Chlorine atoms are green.

While reductive dechlorination is an attractive means for biodegrading the chlorinated alkanes and alkenes, it has a number of serious challenges that must be understood and overcome. The first challenge is that groundwater seldom has an electron donor that can drive reductive dechlorination. The required electron donor is H_2 (i.e., $H_2 + NAD^+ \rightarrow NADH + H^+$) and is almost always supplied by fermentation of a fermentable organic substrate such as lactate, glucose, or molasses. For example, fermentation of lactate typically produces one mol H_2 per mol lactate as shown by Equation (6).



Lactate has ten e^- equivalents, and only two e^- equivalents are routed to H_2 . Glucose is more efficient at routing e^- equivalents to H_2 as shown in Equation (7).

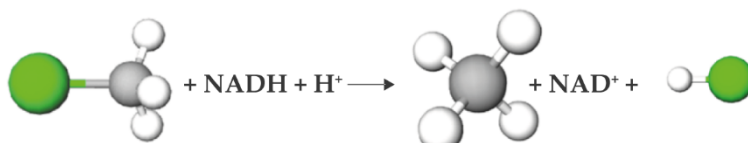
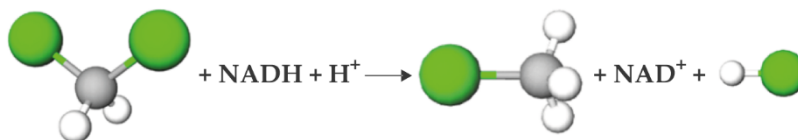
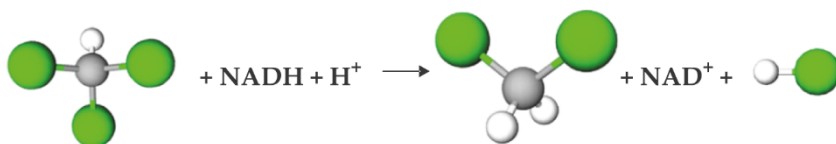
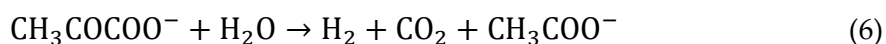
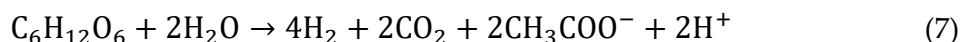

In both cases, most of the electron equivalents are routed to acetic acid, which does not drive reductive dechlorination.

The bacteria known to carry out reductive dechlorination are specialized and not always present or easily enriched. For example, complete reductive dechlorination of TCE is achieved only by *Dehalococcoides mccartyi*. Today, specialized enrichment cultures are often used to ensure that competent dechlorinating bacteria are present.

A related problem is *incomplete* reductive dechlorination, which leaves residual chlorinated contaminants that retain or even amplify the health risks of the original contaminant. The most infamous example is accumulation of vinyl chloride (C_2H_3Cl , a product of the second step in reducing TCE as shown in Figure 15a) from incomplete reduction of TCE or tetrachloroethene. Incomplete reductive dechlorination can occur for five reasons:

1. an insufficient supply of electron donor to produce H_2 ,
2. consumption of H_2 by competing microorganisms utilizing other electron acceptors,
3. lack of bacteria able to achieve complete dechlorination (e.g., *Dehalococcoides mccartyi*),
4. a general slowing of reductive dechlorination kinetics as the number of Cl substituents decreases, and
5. inhibition from any or all of the chlorinated compounds.

As the molecules become more dechlorinated, they can be susceptible to aerobic transformation via co-metabolism involving mono-oxygenases for methane, ethane, toluene, phenol, and even ammonium. In the presence of O_2 and an intracellular electron donor, the mono-oxygenases form an epoxide—which is unstable and chemically transforms to biodegradable products, although it is not necessarily biodegradable by the microorganism having the mono-oxygenase. As the transformation is co-metabolic, the bacteria require another electron-donor substrate ([Exercise 18](#) and [Exercise 19](#)).

7 Chlorinated Aromatics

A wide range of chlorinated aromatics pose environmental threats in groundwater and other settings. Figure 16 shows a few examples of chlorinated aromatics. The simpler molecules, such as the chlorinated benzenes, phenols, and benzoates, are easier to bioremediate. They are moderately to strongly hydrophobic. Those with more Cl substituents are more hydrophobic. For example, K_{ow} is $10^{2.2}$ for 2-chlorophenol, but it is $10^{5.0}$ for pentachlorophenol. Likewise, K_{ow} is $10^{3.6}$ for the dichlorobenzenes, but $10^{5.5}$ for hexachlorobenzene.

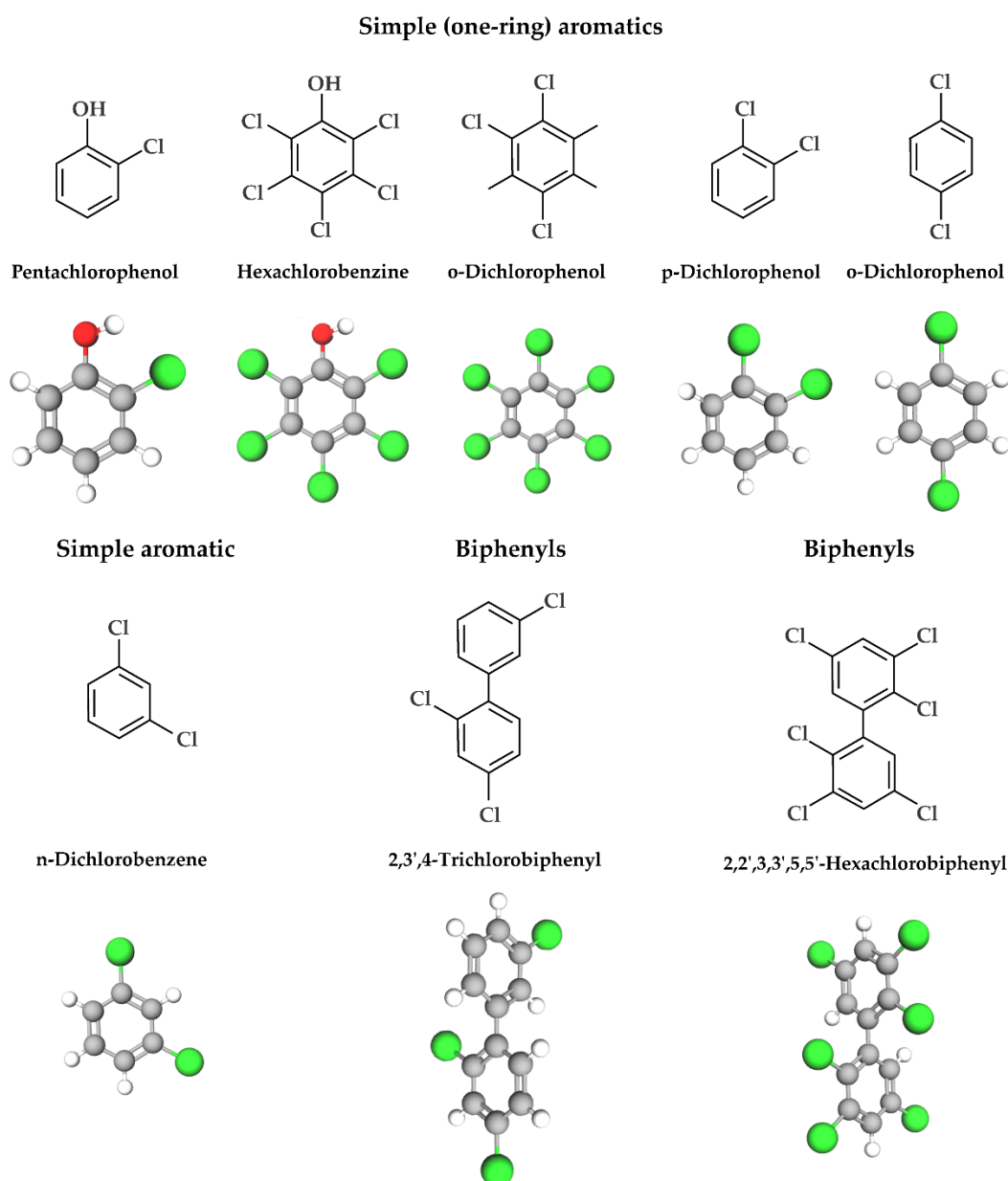
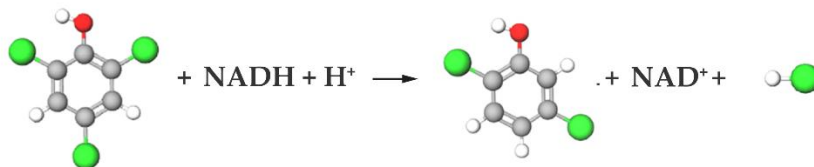
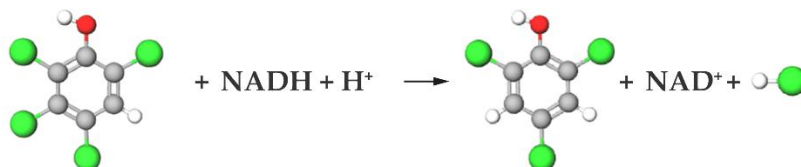
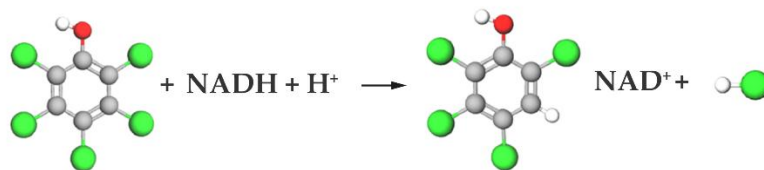

Figure 16 – Common examples of chlorinated aromatics. Simple (one-ring) aromatics and biphenyls that are linked by a C-C bond can have one or many Cl-substituents in the same structure. Oxygen atoms are red and chlorine atoms are green.

Polychlorinated biphenyls (PCBs) are highly carcinogenic chlorinated aromatics with complex structures that give variety to their biotransformation processes. The biphenyl molecule has two benzene rings linked together, and the two rings can be chlorinated at one or up to all ten of its open carbons. The commercially used PCBs, called Aroclor congeners, were mixtures that are identified by a number. The number reflects the degree of Cl substitution of the mixture, with a larger number signifying greater Cl content. PCBs are strongly hydrophobic: for example, $K_{ow} = 10^{5.6}$ for Aroclor 1254, which is one of the most common commercial PCB congeners. Due to their exceptional resistance to fire and outstanding insulation properties, PCBs were used for decades in transformers, capacitors, and hydraulic fluids. However, because of their environmental persistence, bioaccumulation ability, and ecotoxicity, PCBs were banned in the 1970s. Nonetheless, PCBs strong hydrophobicity and resistance to biodegradation cause them to persist today. A notable example is their presence in the sediments of the Hudson River in New York state in the USA, where PCBs were discharged from capacitor manufacturing plants from the late 1940s to the late 1970s.

Similar to the chlorinated alkanes and alkenes, heavily chlorinated aromatics are susceptible to reductive dechlorination, while lightly chlorinated aromatics can be biodegraded aerobically, usually initiated by a mono-oxygenase reaction. Figure 17 provides examples of sequential reductive and oxidative reactions. The reductive reactions require an electron-donor substrate, while the aerobic reactions require O_2 . Inhibition by the parent compound or partially dechlorinated product can impede complete biodegradation.

a) Sequential reductive dechlorination



b) Aerobic di oxygenation

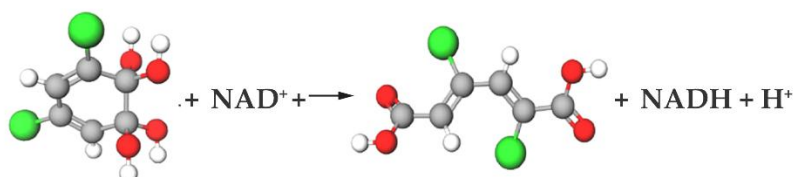
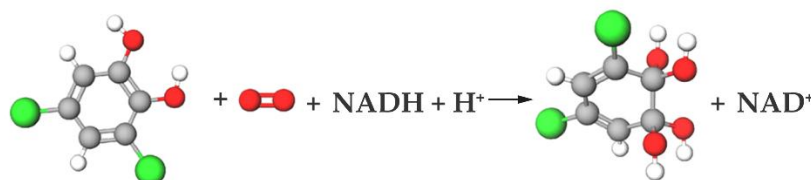
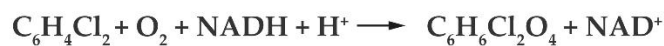
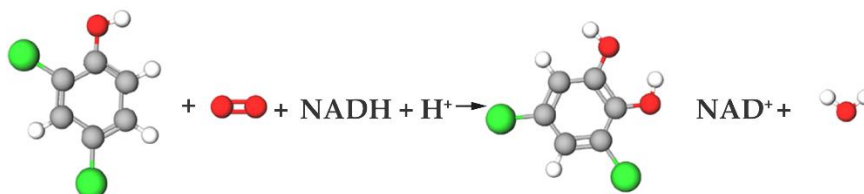
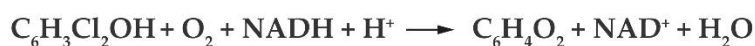

Figure 17 – Bioremediation of pentachlorophenol: a) sequential reductive dechlorination and b) aerobic di-oxygenation. Oxygen atoms are red and chlorine atoms are green.

A special case of chlorinated aromatics is 2,3,7,8-tetrachlorodibenzo-p-dioxin (TCDD), which is usually called *dioxin*. Sometimes called the most toxic substance on the Earth, dioxin was formed incidentally during the manufacture of pesticides. Due to dioxin's presence in pesticides, pesticide-manufacturing wastewater, and dust-suppression oils, humans have been exposed to dioxin with dire health effects. TCDD is exceptionally hydrophobic ($K_{ow} = 10^{6.6}$), which makes it a strong bioaccumulator, but poorly bioavailable for biodegradation.

TCDD can be biodegraded anaerobically or aerobically. Anaerobic biodegradation is via reductive dechlorination that requires an electron donor. Aerobic biodegradation begins with mono- or di-oxygenation, but this often leads to dead-end –OH-containing analogs ([Exercise 20](#) ↴ and [Exercise 21](#) ↴).

8 Energetics

Energetics refer to nitrogen-containing organics that are used in explosives, particularly for military purposes. Wastewater from manufacturing facilities, as well as exploded or unexploded ordnances, are sources of energetics contamination in groundwater. Figure 18 shows structures of some important energetics. All of them have the nitro group ($-\text{NO}_2$), which acts as a potent oxidant for the carbon-based reductant. Thus, the energetics have self-contained components for rapid and strong energy-releasing reactions.

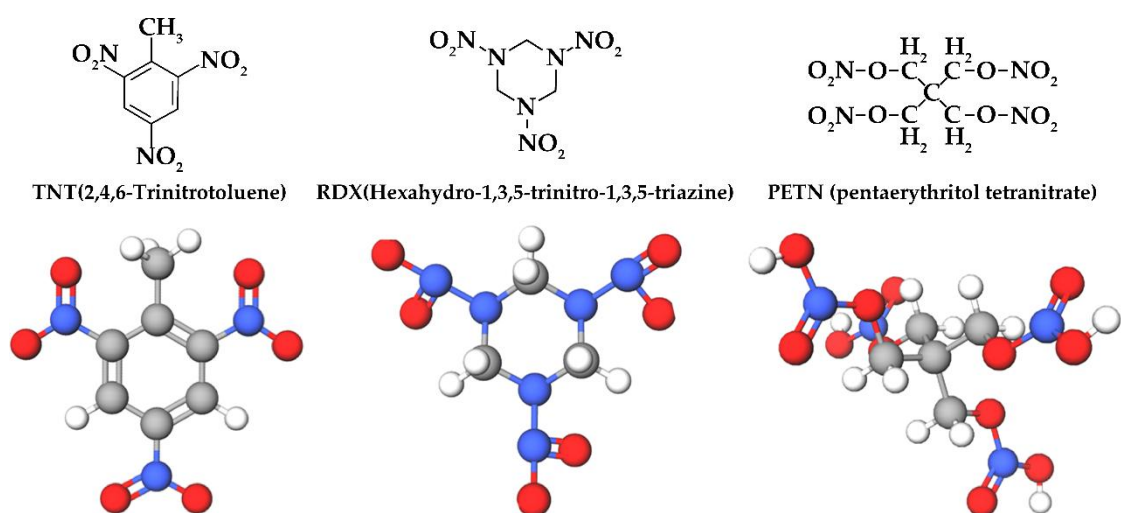

Figure 18 – Structures of important energetics. An energetic has the reductant and oxidant in the same molecule; thus, it is very efficient for rapid combustion/explosion. All these examples have $-\text{NO}_2$ in the structure, which is the oxidant part of the molecule. The carbon in the structure is the reductant part of the molecule. Oxygen atoms are red, nitrogen atoms are blue, and carbon atoms are gray.

The energetics can be biologically transformed. The initial steps are usually reductions of the $-\text{NO}_2$ groups to amino groups ($-\text{NH}_2$), although mono- and di-oxygenations also are possible (Singh et al., 2015). Figure 19 provides an example of stepwise reductions for trinitrotoluene (TNT). In most cases, these amino-containing reduction products do not further biodegrade—although they may polymerize or mix with soil organics to form a complex. Should TNT lose one or two nitro groups, the mononitro- and dinitro-toluenes are susceptible to oxygenation reactions that replace the $-\text{NO}_2$ group with $-\text{OH}$. This can lead to ring cleavage and mineralization, similar to what occurs with oxygenated aromatics.

The heterocyclic energetics (e.g., RDX and HMX, commonly used in solid propellants and chemical explosives for widespread military and commercial purposes) can also be biodegraded. The nitro groups can be reduced to amino groups, but information is sketchy for what happens beyond that ([Exercise 22](#) and [Exercise 23](#)).

Stepwise reductions of a nitro group on TNT

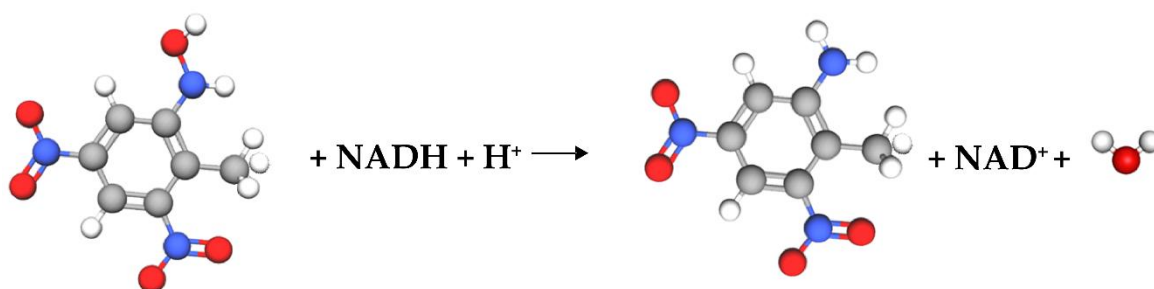
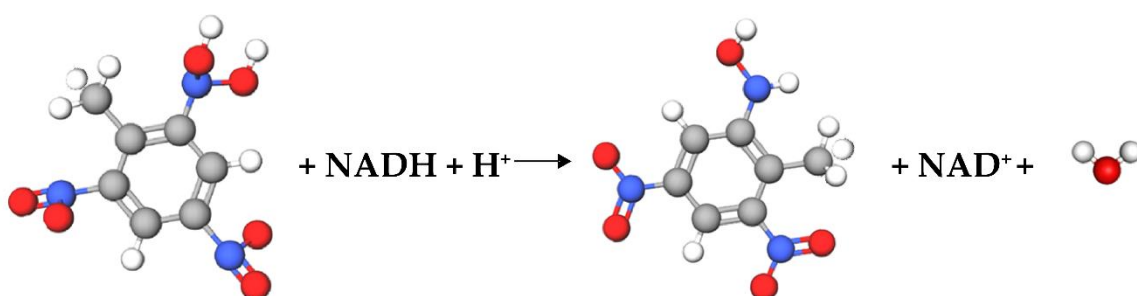
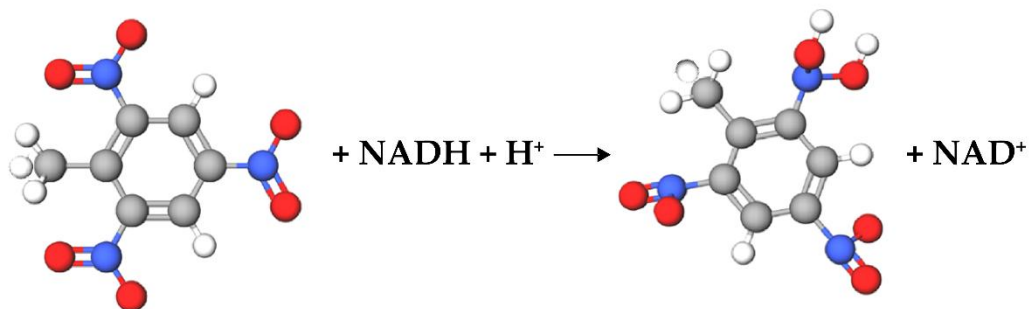
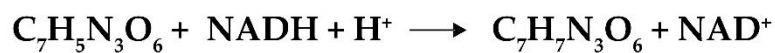

Figure 19 – Examples of stepwise reductions of a nitro group on TNT. NADH + H⁺ adds two e⁻ equivalents. Oxygen atoms are red and nitrogen atoms are blue.

9 Fluorinated Alkyl Substances

Among the most troublesome organics today are the per- and poly-fluorinated alkyl substances (PFAS). Their largest and riskiest use is in fire-fighting foams, particularly at airports and military installations, because they are inevitably dispersed to the environment. The other major sources of PFAS are water and air emissions from manufacturing facilities. Hundreds of PFAS have been used, and their structure, molecular weights, and degrees of fluorination are highly variable.

Figure 20 shows some characteristic PFAS. Most PFAS are highly hydrophobic. For example, one of the most common PFAS, perfluorooctanoic acid (PFOA), has a K_{ow} of $10^{4.8}$.

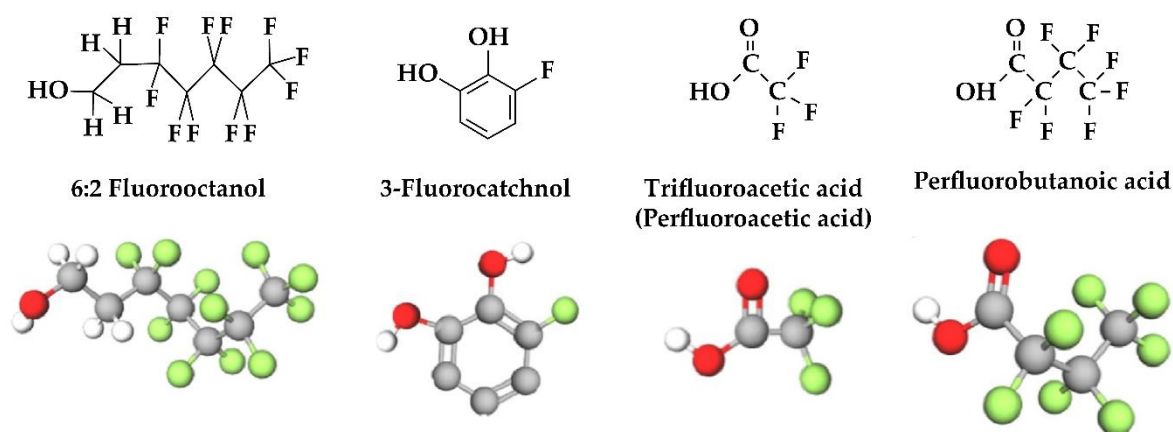

Figure 20 – Structures of characteristic PFAS molecules. Oxygen atoms are red and fluorine atoms in green.

The PFAS often are referred to as the “forever compounds” because they resist breakdown by biological, chemical, or photochemical means. The resistance to breakdown stems from the exceptional strength of the C – F bond. For example, the C – F bond strength is 536 kJ/mol, compared to 397 kJ/mol for the C – Cl bond. Hence, defluorination is much more difficult than dechlorination.

The fluoride substituent is strongly electronegative, which suggests that PFAS could be susceptible to reductive defluorination, similar to reductive dechlorination. However, clear evidence of microbially catalyzed reductive defluorination is absent, at least for the fully fluorinated compounds. Partially fluorinated PFAS can be biodegraded; the mechanism appears to be a form of β -oxidation that also leads to F^- release.

Figure 21 shows a hypothetical pathway for defluorination of perfluorobutanoic acid (used in non-stick and stain-resistant consumer products, food packaging, fire-fighting foam, and industrial processes). The defluorination involves initial reduction steps, followed by β -oxidation coupled with defluorination ([Exercise 24](#)↓).

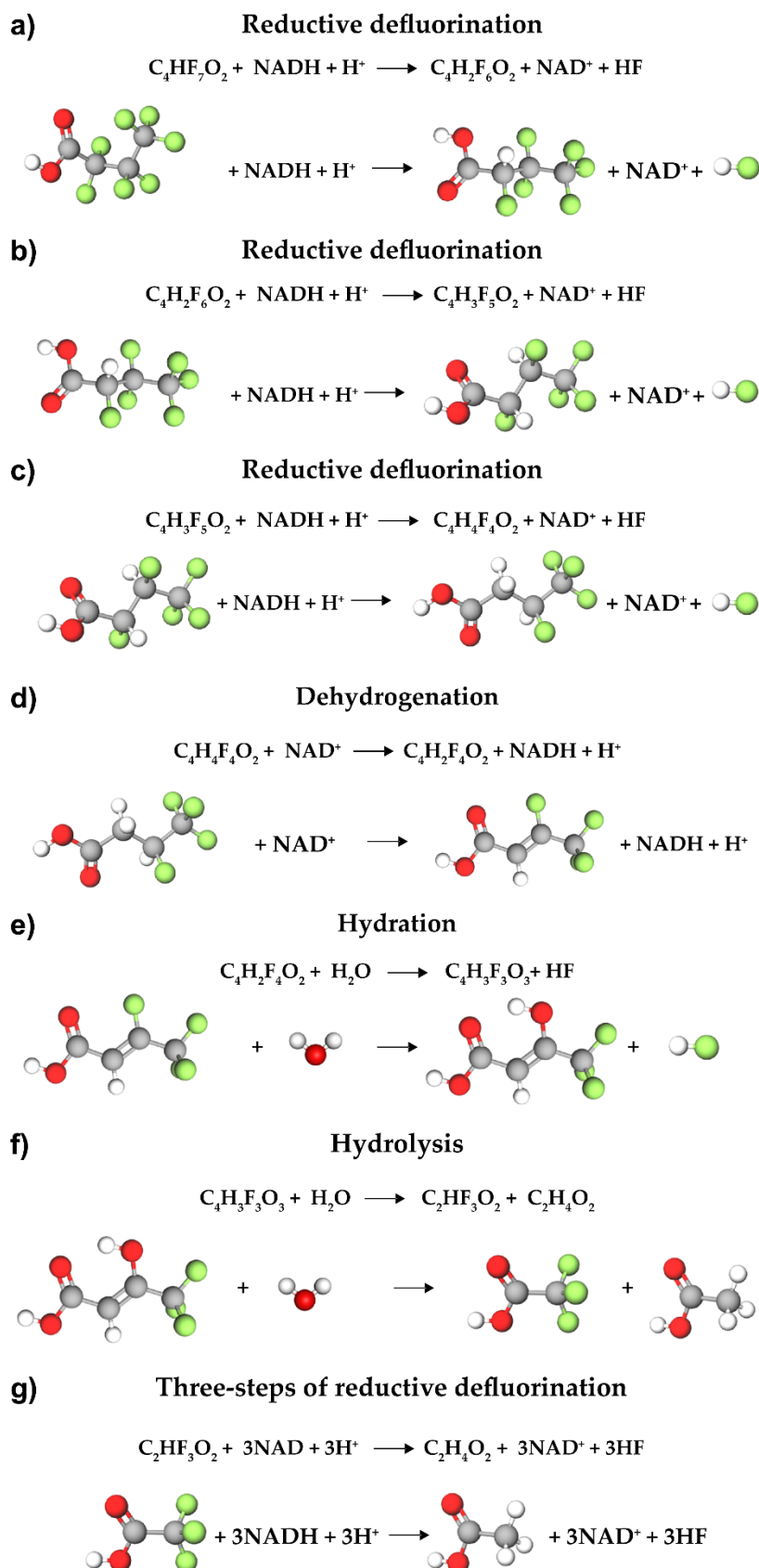

Figure 21 – Hypothetical pathway for defluorination of perfluorobutanoic acid to form two acetic acids ($\text{C}_2\text{H}_4\text{O}_2$): a), b), and c) three reductive defluorinations, d) one dehydrogenation, e) one hydration, f) one hydrolysis and g) three steps of reductive defluorination ultimately producing acetic acid. Oxygen atoms are red and fluorine atoms are green.

10 Wrap Up

The nearly infinite metabolic capacity of microorganisms opens up the opportunity to detoxify a wide range of organic contaminants that occur in groundwater—as long as the proper conditions are established to select and sustain the capable microorganisms. This book outlines the necessary conditions for a range of useful microorganisms.

All microorganisms must have electron-donor and electron-acceptor substrates, and the organic contaminants normally can be either a donor or an acceptor. The biodegradation setting, whether natural or engineered, must provide the other substrate along with a suitable pH and other nutrients. Oxidations of a donor by hydroxylation and dehydrogenation reactions generate electron flow that is directed to acceptor reduction in energy-yielding respiration, which supports biomass growth and maintenance.

Often, an organic contaminant that can be an electron donor must undergo an initial activation reaction before it can participate in the normal catabolic reactions that generate electron flow and energy gain. Good examples are mono- and di-oxygenation reactions that consume electrons and energy but produce intermediates that can be oxidized by normal hydroxylations and dehydrogenations. Once the activation reactions are complete, the intermediates generate electron flow and energy for the microorganisms.

Organic contaminants that can be electron acceptors commonly contain chlorine, fluorine, or nitro substituents. Their biodegradation demands a bioavailable electron-donor substrate such as H₂ or acetic acid, which can be supplied directly or via fermentation of complex organic compounds such as carbohydrates.

Biotransformation will continue to be a mainstay of groundwater remediation. While we already know that microorganisms have vast metabolic diversity to biodegrade organic and inorganic chemicals, rapidly advancing tools from molecular biology and chemistry (i.e., the many *omics*¹) are revealing more about what the microorganisms can do metabolically and how they do it. This new knowledge will allow environmental biotechnologists to envision and implement new and better biotransformation strategies. These advancing capabilities to harness the metabolic power of microorganisms are perfectly suited to help society address the steadily increasing emergence of water pollutants that create risks to human and ecosystem health.

¹ “omics” are disciplines in biology with names ending in *omics* and that collectively characterize and quantify groups of biological molecules that describe the structure, function, and dynamics of a microorganism or a community of microorganisms. For example, genomics describes the structure of the community, while transcriptomics, proteomics, and metabolomics describe different aspects of the community’s function.

11 Exercises

Exercise 1

The standard free energy at pH=7 for oxidation of glucose ($C_6H_{12}O_6$) with reduction of O_2 is $\Delta G^{0'} = 119.70 \text{ kJ/e}^- \text{ eq}$ as shown in Equation (1). The oxidation of acetate ($C_2H_4O_2$) using O_2 is $\Delta G^{0'} = -106.16 \text{ kJ/e}^- \text{ eq}$.

Based on this difference, what are the $\Delta G^{0'}$ values when acetate is oxidized using the acceptors listed in Table 1: Fe^{3+} , NO_3^- , SeO_4^{2-} , SO_4^{2-} , and CO_2 ?

[Solution to Exercise 1](#) ↓

[Return to where text linked to Exercise 1](#) ↑

Exercise 2

- a) The standard free energy at pH = 7 for oxidation of glucose ($C_6H_{12}O_6$) with reduction of O_2 is $\Delta G^{0'} = 119.70 \text{ kJ/e}^- \text{ eq}$ as shown in Equation (1). The oxidation of toluene (C_7H_8) using O_2 is $\Delta G^{0'} = -106.60 \text{ kJ/e}^- \text{ eq}$. Based on this difference, what are the $\Delta G^{0'}$ values when toluene is oxidized using the acceptors listed in Table 1: Fe^{3+} , NO_3^- , SeO_4^{2-} , SO_4^{2-} , and CO_2 ?
- b) Explain why respiration using O_2 or NO_3^- supports microorganisms that have much higher yields and faster specific growth rates than respiration using SO_4^{2-} .

[Solution to Exercise 2](#) ↓

[Return to where text linked to Exercise 2](#) ↑

Exercise 3

The “normal” formula for biomass, $C_5H_7O_2N$, has a formula weight of 113 g/mol. The P content can be added to give $C_5H_7O_2NP_x$. Determine the formula weight of $C_5H_7O_2NP_x$ and the value of x if P adds two percent to the mass.

[Solution to Exercise 3](#) ↓

[Return to where text linked to Exercise 3](#) ↑

Exercise 4

What is the PMF? How is it created? How is it used by the cells?

[Solution to Exercise 4](#) ↓

[Return to where text linked to Exercise 4](#) ↑

Exercise 5

Write out the balanced reaction for the hydroxylation of butanal (a 4-C aldehyde). It may be helpful to review the reactions shown in Figure 4.

[Solution to Exercise 5](#) ↓

[Return to where text linked to Exercise 5](#) ↑

Exercise 6

Write out the balanced reaction for the dehydrogenation of 1-butanol (a 4-C alcohol). It may be helpful to review the reactions shown in Figure 4.

[Solution to Exercise 6](#) ↓

[Return to where text linked to Exercise 6](#) ↑

Exercise 7

Write out the four steps for β -oxidation of 1-butyric acid to two acetic acids. It may be helpful to review the reactions shown in Figure 6.

[Solution to Exercise 7](#) ↓

[Return to where text linked to Exercise 7](#) ↑

Exercise 8

In the citric acid cycle, what are the names and formulas for the 5C and 6C intermediates?

[Solution to Exercise 8](#) ↓

[Return to where text linked to Exercise 8](#) ↑

Exercise 9

Write out the balanced reaction for mono-oxygenation of phenol (C_6H_5OH). It may be helpful to review the reactions shown in Figure 7.

[Solution to Exercise 9](#) ↓

[Return to where text linked to Exercise 9](#) ↑

Exercise 10

- Write out the balanced reaction for the two-step di-oxygenation of toluene ($C_6H_5CH_3$). It may be helpful to review the reactions shown in Figure 7.
- Describe why mono- and di-oxygenation reactions are so effective as initial activation steps for a wide range of organic molecules.

[Solution to Exercise 10](#) ↓

[Return to where text linked to Exercise 10](#) ↑

Exercise 11

Compute S_{min} for four bacteria that have the following kinetic and stoichiometric parameters, using Equation (5).

Kinetic and stoichiometric parameters for the four bacteria				
Parameter	A	B	C	D
K_s , mg contaminant per liter	10	1	1	10
q_{max} , mg contaminant per mg biomass per day	12	6	1	6
Y , mg biomass generated per mg contaminant utilized	0.6	0.5	0.6	0.1
b , decay of biomass, 1 per day	0.2	0.03	0.03	0.1

[Solution to Exercise 11](#) ↓

[Return to where text linked to Exercise 11](#) ↑

Exercise 12

Estimate the change in equilibrium concentration (in mM and g/L) when benzene ($K_{ow} = 10^{2.2} L_{H_2O}/L_{oct}$) is oxidized to phenol ($K_{ow} = 10^{1.5} L_{H_2O}/L_{oct}$) if the equilibrium concentration of benzene is 23 mM (1.8 g/L) at $T = 20\text{ }^\circ\text{C}$.

[Solution to Exercise 12](#) ↓

[Return to where text linked to Exercise 12](#) ↑

Exercise 13

Write out the three steps needed to completely oxidize ethanol ($\text{CH}_3\text{CH}_2\text{OH}$) to two CO_2 . It may be helpful to look back at discussions of dehydrogenation and hydroxylation.

[Solution to Exercise 13](#) ↓

[Return to where text linked to Exercise 13](#) ↑

Exercise 14

MTBE ($(\text{CH}_3)_3\text{COCH}_3$) undergoes two mono-oxygenation reactions to form 1-methyl-1,2-propane-diol ($(\text{CH}_3)_2\text{CH}_2\text{OH}$) and formaldehyde (H_2CO). Write out balanced reactions for each step. The formaldehyde is released in the first step. It may be helpful to review the reactions shown in Figure 7.

[Solution to Exercise 14](#) ↓

[Return to where text linked to Exercise 14](#) ↑

Exercise 15

Write out the set of sequential dehydrogenation, hydroxylation, and hydrolysis reactions that convert 1-methy-1,2-propane diol $((\text{CH}_3)_2\text{CH}_2\text{OH})$ to 2,2-propane diol $((\text{CH}_3)_2\text{C}(\text{OH})_2)$ and formaldehyde (H_2CO) . The formaldehyde is released in the third step.

[Solution to Exercise 15](#) ↓

[Return to where text linked to Exercise 15](#) ↑

Exercise 16

a) As shown in Figure 9, the biodegradation of 1,4-dioxane ($\text{C}_4\text{H}_8\text{O}_2$) begins with two mono-oxygenations, dehydrogenation, and hydrolysis. The overall reaction for this is

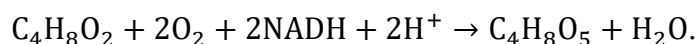

- i. Write the overall reaction for the complete mineralization of $\text{C}_4\text{H}_8\text{O}_5$ to 4CO_2 .
 - ii. Then, compute the fraction of electron equivalents present in 1,4-dioxane that are recovered in $\text{NADH} + \text{H}^+$ when the reaction begins with 1,4-dioxane and ends with CO_2 .
- b) Mineralization of phenol ($\text{C}_6\text{H}_5\text{OH}$) begins with two mono-oxygenation reactions that cleave the phenol. The mono-oxygenation product is then oxidized by normal dehydrogenation and hydroxylation reactions. Write out the two mono-oxygenation reactions and then the sum of all downstream reactions, assuming that O_2 is the terminal electron acceptor for respiration.
- i. If 1 mol phenol is mineralized by this scheme, how much O_2 is consumed in total?
 - ii. How much of that O_2 is used for respiration versus mono-oxygenation?
- c) Using the same set up as b), consider that NO_3^- reduction to N_2 is used for respiration instead of O_2 reduction to H_2O . The initial mono-oxygenations utilize O_2 .
- i. If 1 mol phenol is mineralized by this scheme, how much NO_3^- is consumed in total?
 - ii. How much of the electron equivalents contained in phenol are used for NO_3^- respiration versus mono-oxygenation?

[Solution to Exercise 16](#) ↓

[Return to where text linked to Exercise 16](#) ↑

Exercise 17

Write out the series of reductive-dechlorination reactions to take 1,1,1-trichloroethane (TCA) to ethane. It may be helpful to review the reactions shown in Figure 15.

[Solution to Exercise 17](#) ↓

[Exercise 17](#) ↑

Exercise 18

- a) Trichloroethene (TCE) is to be reductively dechlorinated to ethene. The electron donor is to come from lactate fermentation to H_2 and CH_3COOH . If 1 mol TCE is to be fully reduced, how many moles of lactate are needed if no competing reactions consume lactate or its fermentation products? It is useful to recall that only the H_2 can be used to drive the reductive dechlorination of TCE.
- b) Reductive dechlorination of TCE is to be driven by fermentation of lactate (CH_3COCO_2H) to H_2 + acetate. The water contains 0.1 mol TCE and 10 mol SO_4^{2-} as electron acceptors.

- i. How many moles of lactate are needed to reduce TCE to ethene?
- ii. How many extra moles of lactate are needed to reduce SO_4^{2-} to H_2S ?

It is useful to recall that only H_2 can be used for TCE reduction, but H_2 and acetate can be used to reduce SO_4^{2-} .

- c) Reductive dechlorination of TCE is to be driven by fermentation of lactate (CH_3COCO_2H) to H_2 + acetate. The water contains 0.2 mol TCE and 5 mol CO_2 as electron acceptors.
- i. How many mols of lactate are needed to reduce TCE to ethene?
 - ii. How many extra mols of lactate are needed to generate CH_4 from reduction of all of the CO_2 ?
 - iii. How many mols of CH_4 are produced by H_2 reduction of CO_2 plus an acetate cleavage?

It is useful to recall that only H_2 can be used for TCE reduction, but H_2 and acetate can be used to generate CH_4 .

[Solution to Exercise 18](#) ↓

[Return to where text linked to Exercise 18](#) ↑

Exercise 19

If 2 moles of lactate are added per 1 mol TCE to supply an electron donor via fermentation with the aim of achieving TCE reductive dechlorination, what is the most likely product of TCE reduction? It may be helpful to review the reactions shown in Figure 15.

[Solution to Exercise 19](#) ↓

[Return to where text linked to Exercise 19](#) ↑

Exercise 20

Hexachlorobenzene (C_6Cl_6) can be reductively dechlorinated to *o*-dichlorobenzene. Write out the sequence of four reductive dechlorination reactions. It may be helpful to review the reactions shown in Figure 17.

[Solution to Exercise 20](#) ↓

[Return to where text linked to Exercise 20](#) ↑

Exercise 21

o-dichlorobenzene ($C_6H_4Cl_2$) can be aerobically broken down via mono-oxygenation reactions. Write out two sequential mono-oxygenations leading to a dichlorobenzene-diol. It may be helpful to review the reactions shown in Figure 13.

[Solution to Exercise 21](#) ↓

[Return to where text linked to Exercise 21](#) ↑

Exercise 22

Write out the set of reactions that fully reduces one nitro group on RDX: $C_3N_3(NO_2)_3$. It may be helpful to review the reactions shown in Figure 19.

[Solution to Exercise 22](#) ↓

[Return to where text linked to Exercise 22](#) ↑

Exercise 23

Nitrotoluene ($C_6H_4CH_3NO_2$) can be mono-oxygenated to methylbenzol (C_6H_3OH). Write out the reaction. It may be helpful to review the reactions shown in Figure 7.

[Solution to Exercise 23](#) ↓

[Return to where text linked to Exercise 23](#) ↑

Exercise 24

3-fluorocatechol ($C_6H_3(OH)_2F$) can be broken down in a three-step process of hydrolytic defluorination and a two-step di-oxygenation with ring cleavage. Write out these reactions. It may be helpful to review the reactions shown in Figure 21.

[Solution to Exercise 24](#) ↓

[Return to where text linked to Exercise 24](#) ↑

12 References

- Ferris, F. G., Szponar, N., & Edwards, B. A. (2021). *Groundwater microbiology*. The Groundwater Project. <https://gw-project.org/books/groundwater-microbiology/>.
- Madigan, M. T., Bender, K. S., Buckley, D. H., Sattley, W. M., & Stahl, D. A. (2019). *Brock biology of microorganisms* (15th ed.). Pearson.
- Moyer, E. E., & KostECKI, P. T. (2003). *Handbook for managing releases of gasoline containing MTBE*. Association for Environmental Health and Sciences.
- National Research Council (NRC). (1993). *In situ bioremediation: When does it work?* The National Academies Press. <https://doi.org/10.17226/2131>.
- National Research Council (NRC). (2000). *Natural attenuation for groundwater remediation*. The National Academy Press. <https://doi.org/10.17226/9792>.
- Rittmann, B. E., & McCarty, P. L. (2020). *Environmental biotechnology: Principles and applications* (2nd ed.). McGraw-Hill. <https://www.accessengineeringlibrary.com/content/book/9781260441604>.
- Rittmann, B. E., Seagren, E., Wrenn, B. A., Valocchi, A. J., Ray, C., & Raskin, L. (1994). *In situ bioremediation* (2nd ed.). Noyes Publishers.
- Singh, D., Mishra, D., & Ramanathan, G. (2015). Bioremediation of nitroaromatic compounds. In M. Samer (Ed.), *Wastewater treatment engineering* (pp. 51–83). IntechOpen. <https://doi.org/10.5772/59384>.
- Wackett, L. P., & Robinson, S. L. (2020). The ever-expanding limits of enzyme catalysis and biodegradation: Polyaromatic, polychlorinated, polyfluorinated, and polymeric compounds. *Biochemical Journal*, 477(15), 2875–2891. <https://doi.org/10.1042/BCJ20190720>.

13 Exercises Solutions

Solution Exercise 1

The difference in $\Delta G^{0'}$ values for oxidation of glucose and oxidation of acetate is $119.70 - 106.15 = 13.55 \text{ kJ/e}^- \text{ eq}$. This means that for oxidation of acetate, all $\Delta G^{0'}$ values in Table 1 of Section 2.1 should be made more positive by $13.55 \text{ kJ/e}^- \text{ eq}$.

$\Delta G^{0'}$ values when acetate is the electron donor	
Acceptor	$\Delta G^{0'}, \text{ kJ/e}^- \text{ eq}$
O_2 to H_2O	-106.15
Fe^{3+} to Fe^{2+}	-101.65
NO_3^- to N_2	-99.65
Se_4^{2-} to Se_0	-59.05
SO_4^{2-} to H_2S	-6.55
CO_2 to CH_4	-3.85

This illustrates the thermodynamic advantage of glucose over acetate as the electron donor.

[Return to Exercise 1](#) ↑

[Return to where text linked to Exercise 1](#) ↑

Solution Exercise 2

- a) The difference in $\Delta G^{0'}$ values for oxidation of glucose and oxidation of toluene is $119.70 - 106.60 = 13.10 \text{ kJ/e}^- \text{ eq}$. This means that all $\Delta G^{0'}$ values in Table 1 of Section 2.1 should be made more positive by $13.10 \text{ kJ/e}^- \text{ eq}$.

$\Delta G^{0'}$ values when toluene is the electron donor.	
Acceptor	$\Delta G^{0'}, \text{kJ/e}^- \text{ eq}$
O_2 to H_2O	-106.6
Fe^{3+} to Fe^{2+}	-102.1
NO_3^- to N_2	-100.1
Se_4^{2-} to Se_0	-59.5
SO_4^{2-} to H_2S	-7.0
CO_2 to CH_4	-4.3

There is a thermodynamic advantage of glucose over toluene as the electron donor, but comparing this result to the Solution of Exercise 1 reveals that toluene is slightly superior as a source of energy when compared to acetate.

- b) Table 1 of Section 2.1 shows that the free-energy gain from respiration of O_2 and NO_3^- ranges from -113 to $-120 \text{ kJ/e}^- \text{ eq}$ when the electron donor is a carbohydrate. In contrast, the free-energy gain from respiring SO_4^{2-} is only about $-20 \text{ kJ/e}^- \text{ eq}$. This means that the energy yield per electron equivalent of donor is up to six-fold smaller for SO_4^{2-} , and this translates directly into a smaller biomass yield, which is about six-fold smaller; the specific growth rate must be commensurately smaller, too.

An analogy can be made to an employee's salary. If employee A has a salary that is six-fold greater than employee B, employee A can afford to grow their "nest egg" at a much faster rate.

[Return to Exercise 2](#) ↑

[Return to where text linked to Exercise 2](#) ↑

Solution Exercise 3

Adding two percent to the mass, the formula weight goes from 113 to:

$$113 \times 1.02 = 115.3 \text{ g/mol}$$

The difference is 2.3 g/mol. Assuming the mass change is all due to addition of phosphorus (P) and, from data on the elements, finding that a mole of P is 31 g, then the number of moles of P required to change the mass by 2 percent is as follows.

$$\frac{2.3 \text{ g}}{\text{mol of biomass}} \left(\frac{1 \text{ mol P}}{31 \text{ g}} \right) = 0.074 \frac{\text{mol P}}{\text{mol biomass}}$$

Thus, the new formula is:

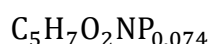

[Return to Exercise 3](#) ↑

[Return to where text linked to Exercise 3](#) ↑

Solution Exercise 4

The PMF is the *proton motive force*, which is a free-energy gradient between the outside and the inside of the cell's membrane. The free-energy gradient is produced because the outside of the membrane has a higher H^+ concentration (lower pH) due to the export of protons to the outside as electrons transfer along the electron-transport chain in the membrane. The import of H^+ across the energy gradient drives the production of ATP from ADP plus phosphate. Thus, the PMF enables energy conservation by transporting electrons to the terminal electron acceptor.

[Return to Exercise 4](#) ↑

[Return to where text linked to Exercise 4](#) ↑

Solution Exercise 5

The formula for butanal is $\text{CH}_3\text{CH}_2\text{CH}_2\text{CHO}$.

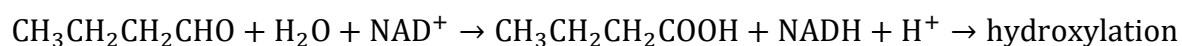

[Return to Exercise 5](#) ↑

[Return to where text linked to Exercise 5](#) ↑

Solution Exercise 6

The formula for 1-butanol is $\text{CH}_3\text{CH}_2\text{CH}_2\text{CH}_2\text{OH}$.

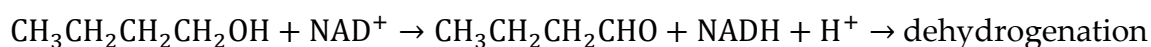

[Return to Exercise 6](#) ↑

[Return to where text linked to Exercise 6](#) ↑

Solution Exercise 7

The formula for 1-butyric acid is $\text{CH}_3\text{CH}_2\text{CH}_2\text{COOH}$.

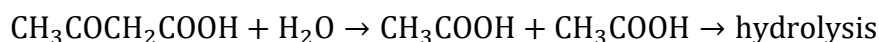
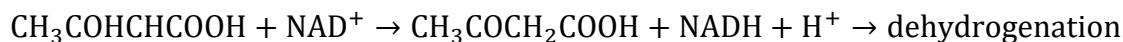

[Return to Exercise 7](#) ↑

[Return to where text linked to Exercise 7](#) ↑

Solution Exercise 8

5-C intermediate: α -ketoglutarate, $\text{C}_6\text{H}_6\text{O}_5$

6-C intermediate: citric acid, $\text{C}_6\text{H}_7\text{O}_6$

[Return to Exercise 8](#) ↑

[Return to where text linked to Exercise 8](#) ↑

Solution Exercise 9

Mono-oxygenation of phenol:

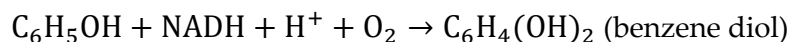

[Return to Exercise 9](#) ↑

[Return to where text linked to Exercise 9](#) ↑

Solution Exercise 10

a) Di-oxygenation of toluene in two steps:

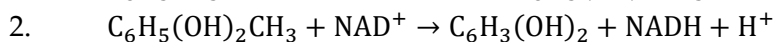
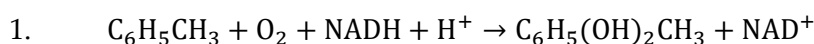

b) Mono- and di-oxygenation reactions are effective as activation reactions because they change the molecules in two ways that make them more susceptible to microbial metabolisms. Both effects stem from introducing O into the molecule.

- First, the introduction of O, such as in hydroxyl ($-\text{OH}$) or carboxylate ($-\text{COOH}$) groups, opens up the possibility of the microorganism being able to utilize common dehydrogenation and hydroxylation reactions, which generate $\text{NADH} + \text{H}^+$ for respiration and biomass synthesis.
- Second, the addition of O makes the molecules less hydrophobic, which increases their availability.

[Return to Exercise 10](#) ↑

[Return to where text linked to Exercise 10](#) ↑

Solution Exercise 11

$$\text{Computing } S_{min} = \frac{K_s b}{(Y q_{max}) - b}$$

Parameters needed to compute S_{min} for the exercise.				
Parameter	A	B	C	D
K_s , mg contaminant per liter	10	1	1	10
q_{max} , mg biomass per mg contaminant per day	12	6	1	6
Y , mg biomass generated per mg contaminant utilized	0.6	0.5	0.6	0.1
b , decay of biomass per day	0.2	0.03	0.03	0.1
S_{min} , mg contaminant per liter	0.029	0.10	0.053	2

[Return to Exercise 11](#) ↑

[Return to where text linked to Exercise 11](#) ↑

Solution Exercise 12

The change in equilibrium concentration is proportional to the change in K_{ow} :

$$\frac{K_{ow-phenol}}{K_{ow-benzene}} = \frac{10^{1.5}}{10^{2.2}} = 10^{-0.7} = 0.2$$

Therefore, the relative solubility of phenol is 1/0.2. This is 5-fold greater than the solubility of benzene in molar concentration.

Given that the concentration of benzene is 23 mM and the molecular weight of benzene 78 g/mol, the mass of benzene per liter is as follows.

$$\frac{23 \text{ mmol}}{\text{liter}} \frac{1 \text{ mol}}{1000 \text{ mmol}} 78 \frac{\text{g} - \text{benzene}}{\text{mol}} = 1.8 \frac{\text{g}}{\text{L}} \text{ benzene}$$

Five times as much phenol can dissolve, which is 115 mM. The molecular weight of phenol is 94 g/mol.

$$\frac{115 \text{ mmol}}{\text{liter}} \frac{1 \text{ mol}}{1000 \text{ mmol}} 94 \frac{\text{g} - \text{phenol}}{\text{mol}} = 10.8 \frac{\text{g}}{\text{L}} \text{ phenol}$$

$$\frac{10.8 \frac{\text{g}}{\text{L}} \text{ phenol}}{1.8 \frac{\text{g}}{\text{L}} \text{ benzene}} = \text{phenol is 6 times more soluble on a mass basis}$$

[Return to Exercise 12](#) ↑

[Return to where text linked to Exercise 12](#) ↑

Solution Exercise 13

Three-step pathway for ethanol mineralization:

1. $\text{CH}_3\text{CH}_2\text{OH} + \text{NAD}^+ \rightarrow \text{CH}_3\text{CHO} + \text{NADH} + \text{H}^+ \rightarrow$ dehydrogenation
2. $\text{CH}_3\text{CHO} + \text{H}_2\text{O} + \text{NAD}^+ \rightarrow \text{CH}_3\text{COOH} + \text{NADH} + \text{H}^+ \rightarrow$ hydroxylation
3. $\text{CH}_3\text{COOH} + 4\text{NAD}^+ + 2\text{H}_2\text{O} \rightarrow 2\text{CO}_2 + 4\text{NADH} + 4\text{H}^+ \rightarrow$ citric acid cycle

[Return to Exercise 13](#) ↗

[Return to where text linked to Exercise 13](#) ↗

Solution Exercise 14

MTBE mono-oxygenations to 1-methyl-1,2-propanediol and formaldehyde (H_2CO):

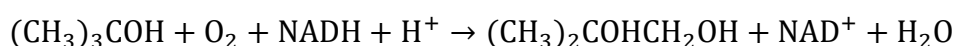
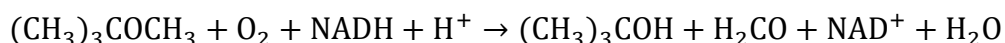

[Return to Exercise 14](#) ↗

[Return to where text linked to Exercise 14](#) ↗

Solution Exercise 15

Three steps from 1-methyl-1,2-propanediol to ethane diol and formic acid (HCOOH):

1. $(\text{CH}_3)_2\text{COHCH}_2\text{OH} + \text{NAD}^+ \rightarrow (\text{CH}_3)_2\text{COHCHO} + \text{NADH} + \text{H}^+ \rightarrow$ dehydrogenation
2. $(\text{CH}_3)_2\text{COHCHO} + \text{H}_2\text{O} + \text{NAD}^+ \rightarrow (\text{CH}_3)_2\text{COHCOOH} + \text{NADH} + \text{H}^+ \rightarrow$ hydroxylation
3. $(\text{CH}_3)_2\text{COHCOOH} + \text{H}_2\text{O} \rightarrow (\text{CH}_3)_2\text{C}(\text{OH})_2 + \text{HCOOH} \rightarrow$ hydrolysis

[Return to Exercise 15](#) ↗

[Return to where text linked to Exercise 15](#) ↗

Solution Exercise 16

a)

i. The initial four reactions result in the following.

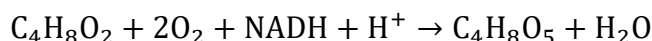

The full mineralization of $\text{C}_4\text{H}_8\text{O}_5$ is as follows.

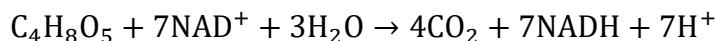

Then the net reaction is as follows.



ii. If dioxane were mineralized directly with recovery of $\text{NADH} + \text{H}^+$, the overall reaction would be as follows.

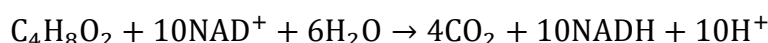

Thus, 60 percent (i.e., 6 out of 10 NADHs) are recovered. This means that the initiation cost is 40 percent of the electron equivalents in 1,4-dioxane.

b) Mineralization of phenol

Mono-oxygenation 1:

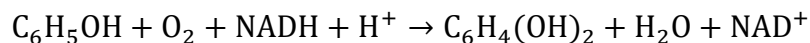

Mono-oxygenation 2:

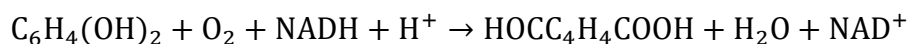

Dehydrogenations and hydroxylations:



Overall (sum of above):

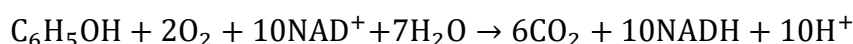

Overall, without considering mono-oxygenations:

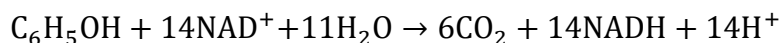

Substituting respiration of $\text{O}_2 + 2\text{NADH} + 2\text{H}^+ \rightarrow 2\text{H}_2\text{O} + \text{NAD}^+$, both overall reactions together are:

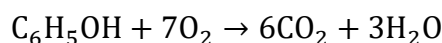

i. The reactions (sum of mono-oxygenations, dehydrogenations, and hydroxylations) yield a net of ten NADH, while oxidation without the mono-oxygenations would yield 14 NADH.

ii. This means that $4/14 = 28.5$ percent of the electron equivalents originally in phenol are “invested” to start the process, while 71.5 percent of the electrons go to respiration and biomass synthesis. When O_2 is the terminal electron acceptor, 71.5 percent of its use is for respiration, but 28.5 percent is for activating mono-oxygenations.

- c) The reactions in b) remain correct. The difference is that the net generated $\text{NADH} + \text{H}^+$ goes to NO_3^- reduction to N_2 as follows.

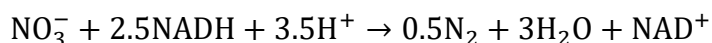

This then gives an overall reaction that includes initial mono-oxygenations and NO_3^- respiration.

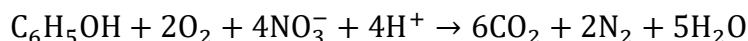

Again $8/28 = 28.5$ percent of the electron equivalents originally in phenol go to O_2 reduction via mono-oxygenations, which leaves 71.5 percent of the electrons for NO_3^- respiration and biomass synthesis.

[Return to Exercise 16](#) ↑

[Return to where text linked to Exercise 16](#) ↑

Solution Exercise 17

The three reductive-dechlorination reactions for 1,1,1-TCA to ethane are as follows.

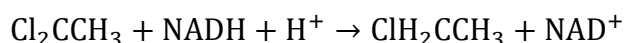
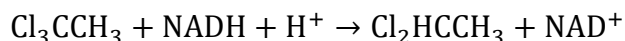

[Return to Exercise 17](#) ↑

[Exercise 17](#) ↑

Solution Exercise 18

a)

The fermentation stoichiometry for lactate is:

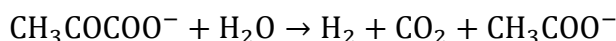

One mol of H_2 is generated per one mol of lactate fermented. Full reductive dechlorination of TCE requires three mols of H_2 . Therefore, the lactate requirement is as follows.

$$1 \text{ mol TCE} \frac{3 \text{ mol H}_2}{1 \text{ mol TCE}} \frac{1 \text{ mol lactate}}{1 \text{ mol H}_2} = \frac{3 \text{ mol lactate}}{1 \text{ mol TCE}}$$

b)

- i. Reduction of 0.1 mol TCE requires 0.6 e^- eq per mol TCE (i.e., 6 e^- eq to remove 3 mol Cl^-). Given that there are 2 e^- eq per mol H_2 , reduction of 0.1 mol TCE requires 0.3 mol H_2 . As fermentation of lactate yields 1 mol H_2 per mol lactate, the reduction of 0.1 mol of TCE requires 0.3 mol lactate.
- ii. As noted after Equation (6), lactate has ten e^- equivalents, and two e^- equivalents are routed to H_2 ; so, 8 out of ten of the e^- equivalents from the lactate fermentation result in acetate. Thus, the TCE reduction produces

$$\frac{8}{10} 0.3 \text{ mol lactate} \frac{10 \text{ e}^- \text{ eq acetate}}{\text{mol lactate}} = 2.4 \text{ e}^- \text{ eq of acetate}$$

that can be used for SO_4^{2-} reduction.

Reduction of 10 mol SO_4^{2-} to H_2S requires 80 e^- eq (i.e., 8 e^- eq per mol SO_4^{2-} to go from oxidation state +6 to -2).

$$\left(10 \text{ mol SO}_4^{2-}\right) \frac{8 \text{ e}^- \text{ eq}}{\text{mol}} = 80 \text{ e}^- \text{ eq}$$

Thus, the demand for lactate for SO_4^{2-} reduction is

$$80 \text{ e}^- \text{ eq} - 2.4 \text{ e}^- \text{ eq (for TCE)} = 77.6 \text{ e}^- \text{ eq of added lactate.}$$

At 10 e^- eq/mol lactate, the added lactate requirement is

$$\frac{77.6 \text{ e}^- \text{ eq}}{10 \text{ e}^- \text{ eq}} = 7.76 \text{ mol lactate for sulfate reduction}$$

Hence, the total lactate demand is

$$0.3 \text{ mol to reduce TCE} + 7.76 \text{ mol to reduce sulfate} = 8.06 \text{ mol lactate.}$$

c)

- i. Reduction of 0.2 mol TCE to ethene requires 1.2 e^- eq/mol TCE (6 e^- equivalents to remove 3 Cl^-). Given that there are 2 e^- eq per mol H_2 , reduction of 0.2 mol TCE requires 0.6 mol H_2 . As fermentation of lactate yields

1 mol H₂ per mol lactate, the reduction of 0.2 mol of TCE requires 0.6 mol lactate.

- ii. Reduction of 5 mol CO₂ to CH₄ requires

$$5 \text{ mol CO}_2 \frac{8 \text{ e}^- \text{ eq}}{\text{mol CO}_2} = 40 \text{ e}^- \text{ eq}$$

- iii. Thus, the total lactate demand is

0.6 mol lactate for TCE reduction + 40 mol lactate for CO₂ reduction = 40.6 mol lactate.

[Return to Exercise 18](#)↑

[Return to where text linked to Exercise 18](#)↑

Solution Exercise 19

Fermentation of lactate yields one mol of H₂ per mol of lactate. TCE full reductive dechlorination requires three mol H₂ per mol TCE. Supplying two mol lactate per mol TCE provides two mol H₂ which is enough electron equivalents to reduce TCE two-thirds of the way to ethene. In this case, the likely reaction is as follows.

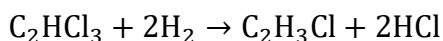

The final product is vinyl chloride.

[Return to Exercise 19](#)↑

[Return to where text linked to Exercise 19](#)↑

Solution Exercise 20

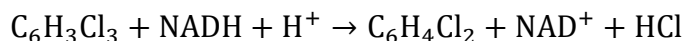
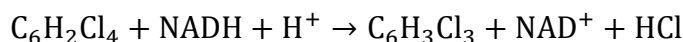
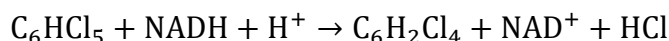
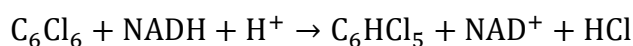

[Return to Exercise 20](#)↑

[Return to where text linked to Exercise 20](#)↑

Solution Exercise 21

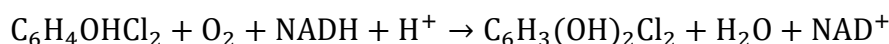
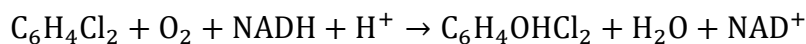

[Return to Exercise 21](#)↑

[Return to where text linked to 21](#)↑

Solution Exercise 22

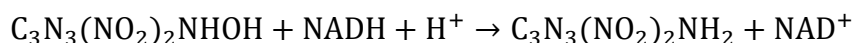
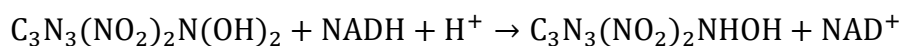
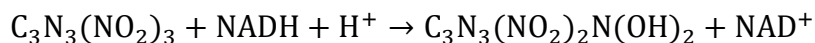

[Return to Exercise 22](#) ↑

[Return to where text linked to Exercise 22](#) ↑

Solution Exercise 23

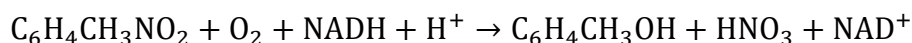

[Return to Exercise 23](#) ↑

[Return to where text linked to Exercise 23](#) ↑

Solution Exercise 24

Hydrolytic defluorination:

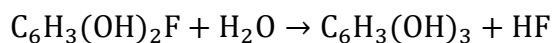

Di-oxygenation step 1:

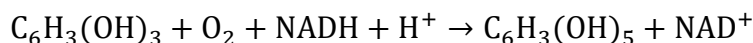

Di-oxygenation step 2, with ring cleavage:

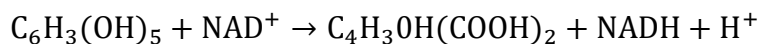

[Return to Exercise 24](#) ↑

[Return to where text linked to Exercise 24](#) ↑

14 Notations

- b = endogenous decay rate representing the loss rate of biomass to maintain themselves (T^{-1})
- $\Delta G^{0'}$ = standard free energy of reaction at $\text{pH} = 7$ normalized to one electron equivalent ($\text{kJ}(\text{e}^- \text{eq})^{-1}$)
- K_S = substrate concentration when the reaction rate is one-half the maximum rate (MsL^{-3}) where M_s represents mass of substrate
- q_{max} = Maximum rate of substrate utilization per mass of substrate utilized ($\text{Ms}(\text{Mx})^{-1}\text{T}^{-1}$) where M_s represents mass of substrate and M_x represents mass of biomass
- Y = true yield, biomass generated per mass of substrate utilized, (MxMs^{-1}) where M_x represents mass of biomass and M_s represents mass of substrate

15 About the Author



Bruce E. Rittmann is Regents Professor of Environmental Engineering and Director of the Biodesign Swette Center for Environmental Biotechnology at Arizona State University. His research focuses on the science and engineering needed to “manage microbial communities to provide services to society.” Services include generating renewable energy, cleaning water and soil, and improving human health. Dr. Rittmann is a member of the US National Academy of Engineering; a Fellow of the American Association for the Advancement of Science (AAAS), Water Environment Federation (WEF), International Water Association (IWA), Association of Environmental Engineering and Science Professors (AEESP), and National Academy of Inventors (NAI); and a Distinguished Member of the American Society of Civil Engineers (ASCE). Dr. Rittmann was awarded the first Clarke Prize for Outstanding Achievements in Water Science and Technology from the National Water Research Institute (NWRI), the Walter Huber Research Prize and the Simon Freese Award from ASCE, the G. M. Fair Award from AAEE, the Camp Applied Research Award from WEF, and the Perry L. McCarty/AEESP Founders Award. He is the co-winner of the 2018 Stockholm Water Prize. Dr. Rittmann has published over 820 journal articles, books, and book chapters; and has 21 patents. With Dr. Perry McCarty, Dr. Rittmann co-authored the textbook *Environmental Biotechnology: Principles and Applications* (McGraw-Hill), which is now in its second edition (2020).

Please consider signing up to the GW-Project mailing list to stay informed about new book releases, events, and ways to participate in the GW-Project. When you sign up to our email list, it helps us build a global groundwater community. [Sign up](#)[↗].

